



www.jaw.com.pl

OBRÓBKI BLACHARSKIE

rysunki poglądowe

2022

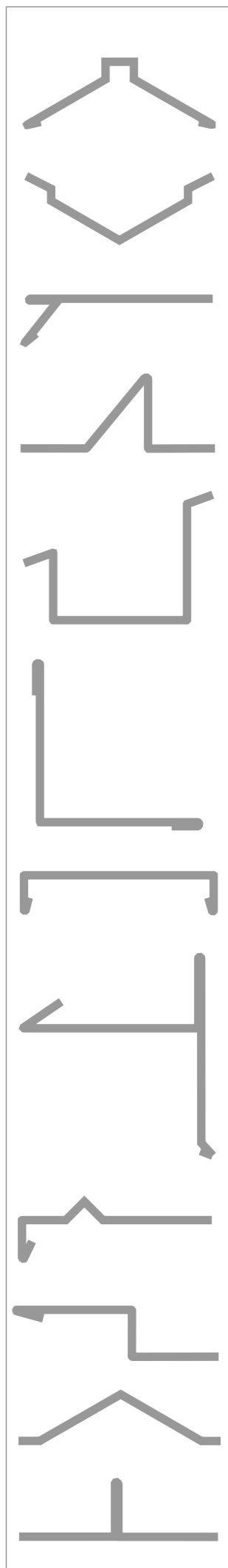

————— Jacek Przyborowski —————

501 608 862

————— Artur Gierasimow —————

501 608 652

————— Waldemar Karpiński —————

506 143 995

————— Witold Kałużny —————

500 255 904

————— JAW Akcesoria Dachowe —————

Ul. Spółdzielców 20

62-510 Konin

JAW

Eksperci Od Dachów

2022

OBRÓBKI BLACHARSKIE



Jak zamówić obróbki ?

narysuj obróbkę
lub wybierz z szablonu



wybierz rodzaj blachy: ocynk, alucynk
stal, tytancynk, miedź, aluminium

określ grubość materiału
obróbki blacharskiej



określ z której strony jest kolor
obróbki blacharskiej

prześlij zamówienie
na email, mms



informacja o wykonaniu: otrzymasz
wiadomość sms, email lub telefonicznie

odbierz obróbki, dostarczymy je
osobiście lub przyślemy kurierem



zamontuj obróbki 



Paleta standardowych kolorów RAL / * kolory pod zamówienie

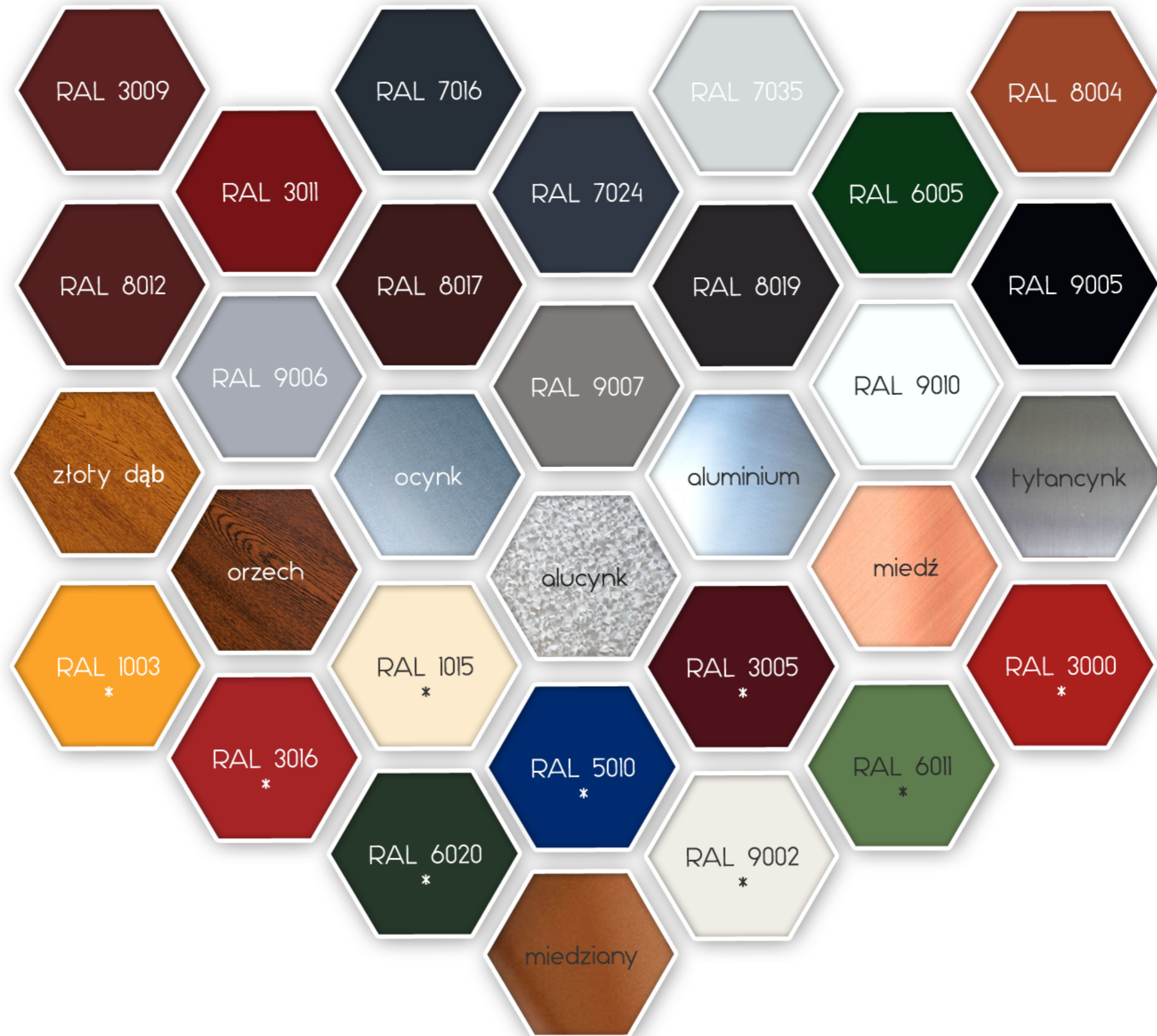

01.

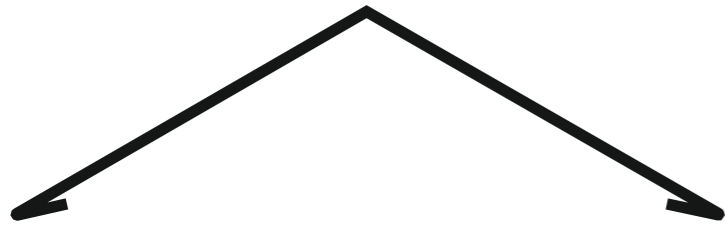

02.

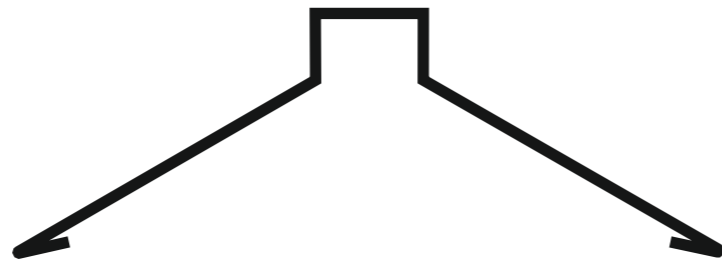

03.

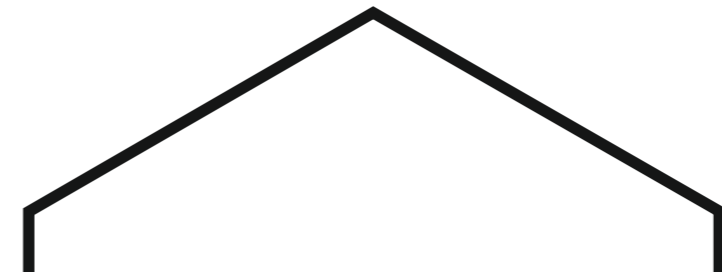

04.

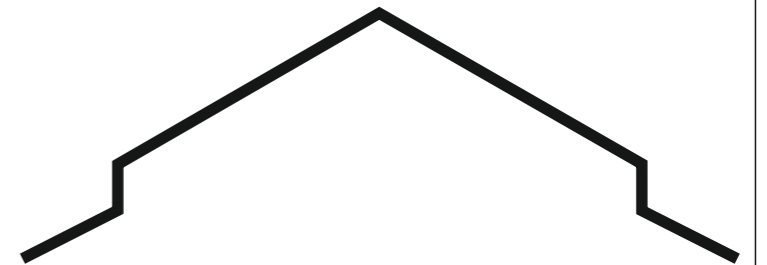

05.

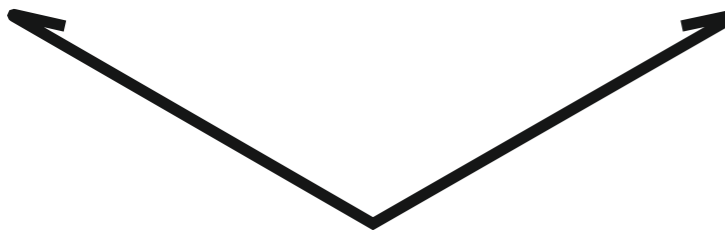

06.

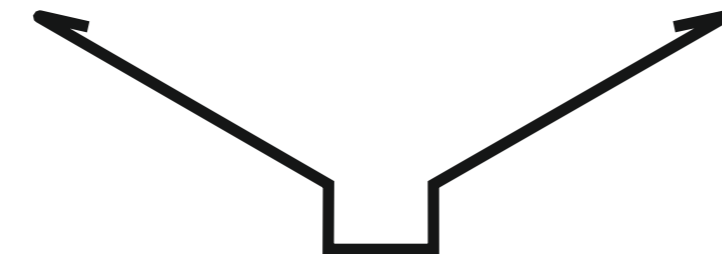

07.

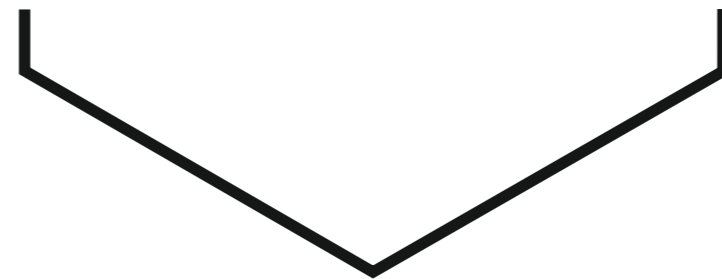

08.

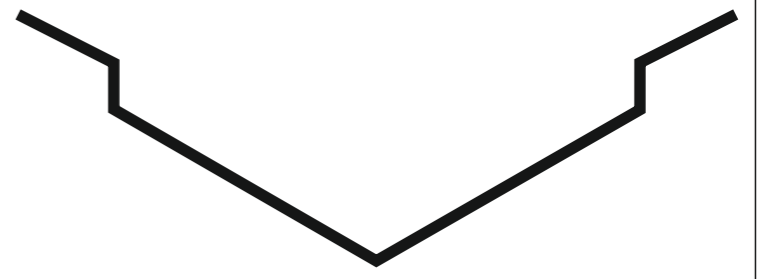

09.

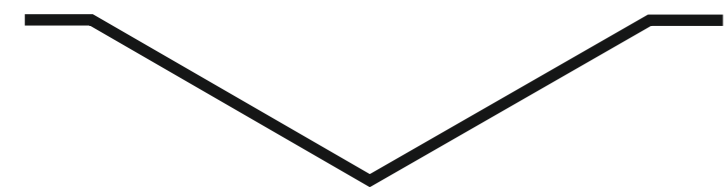

10.



11.



12.



13.

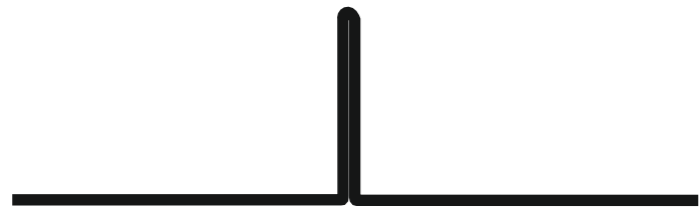

14.

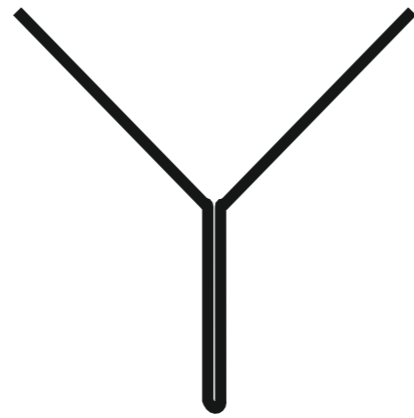

15.

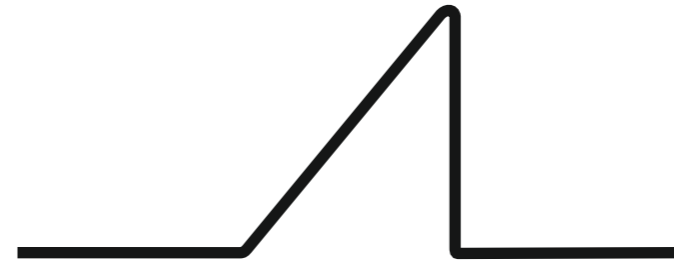

16.



17.



18.

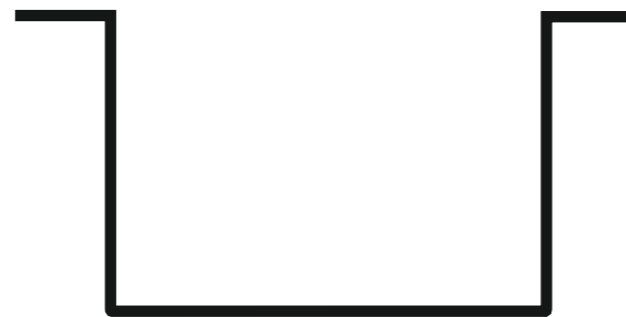

19.

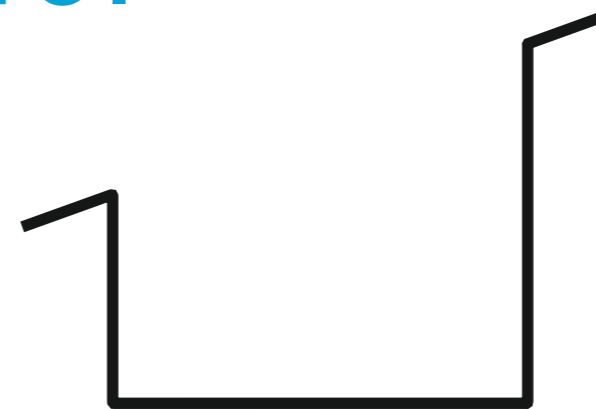

20.



21.

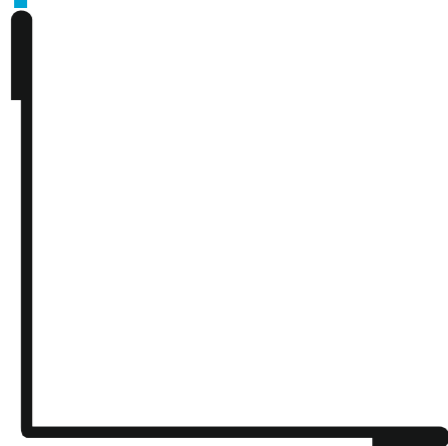

22.

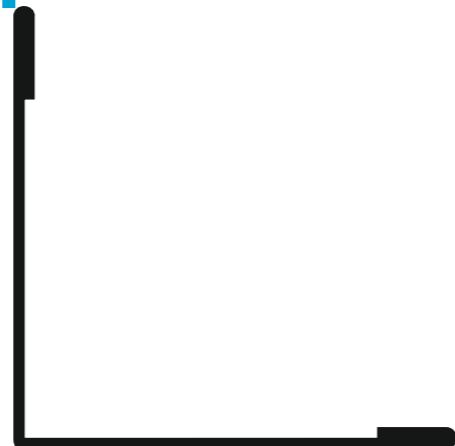

23.

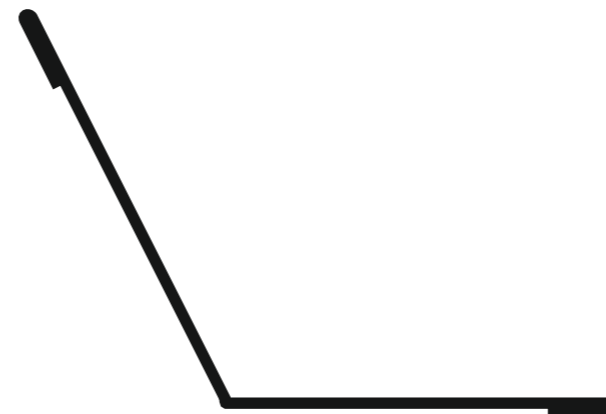

24.



25.

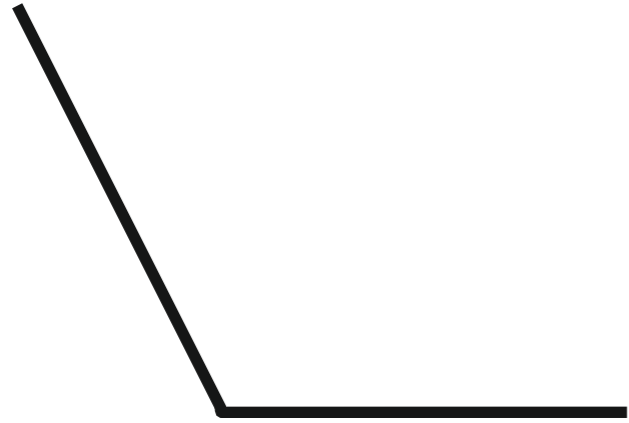

26.

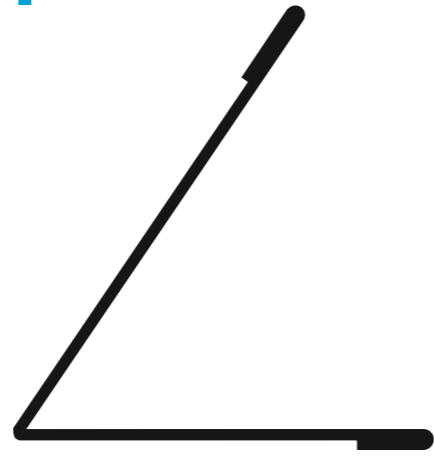

27.



28.



29.



30.



31.



32.



33.



34.



35.



36.

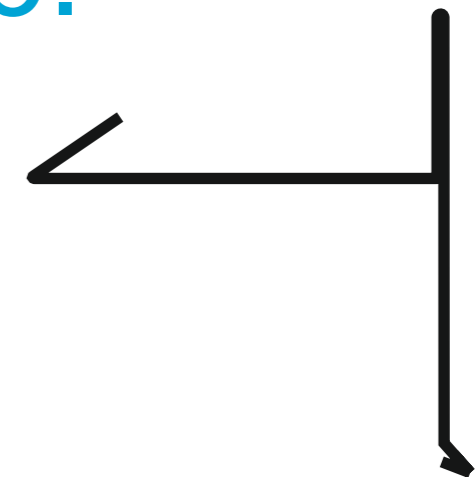

37.

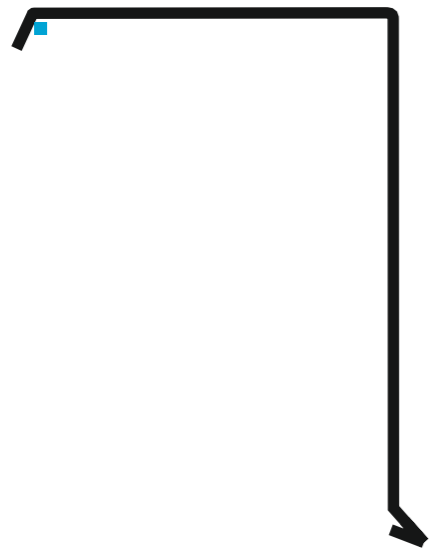

38.



39.



40.

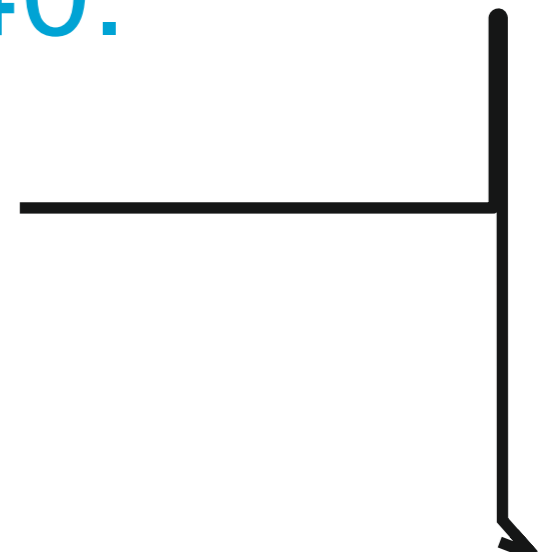

41.

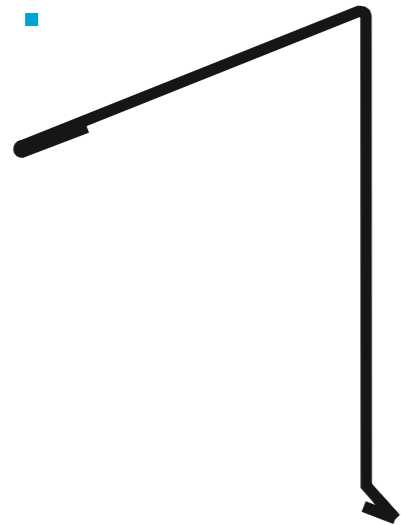

42.

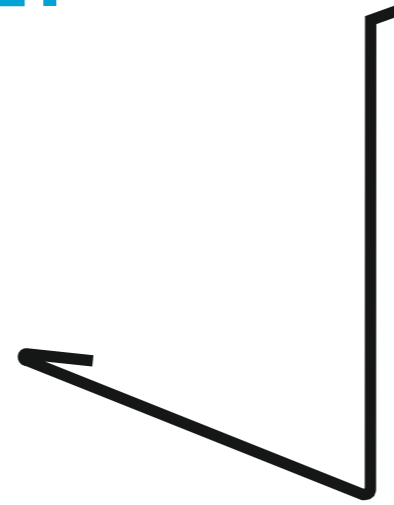

43.

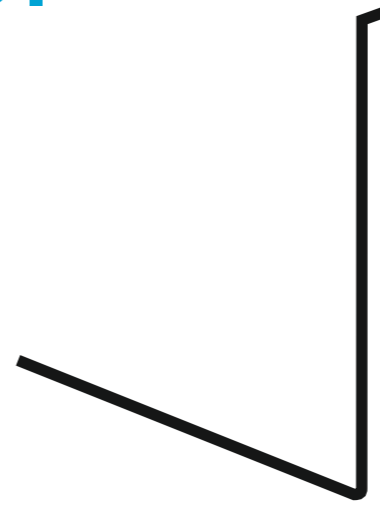

44.

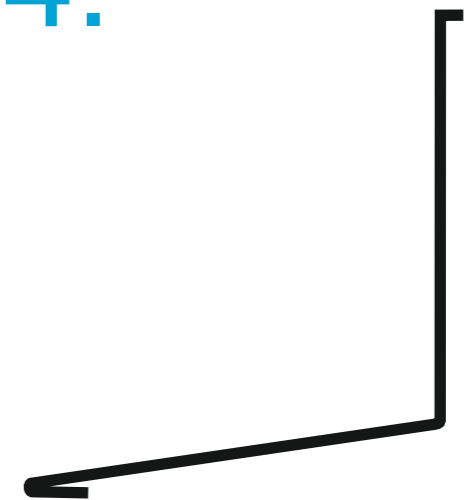

45.

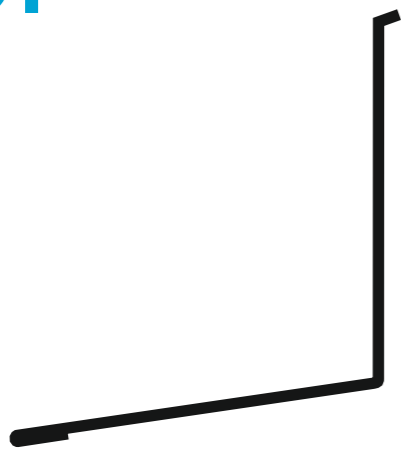

46.

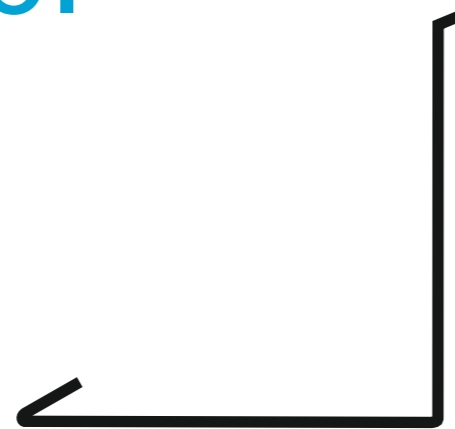

47.

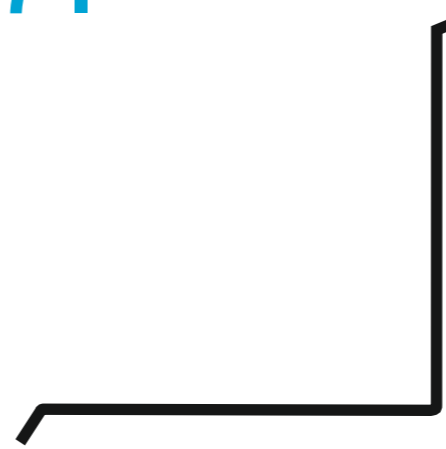

48.



49.



50.



51.



52.



53.



54.



55.



56.



57.

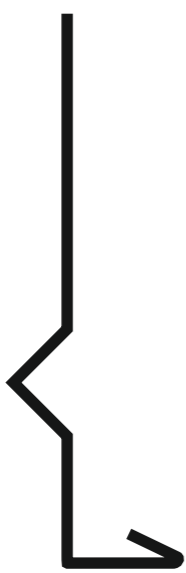

58.



59.



60.



61.



62.



63.



64.

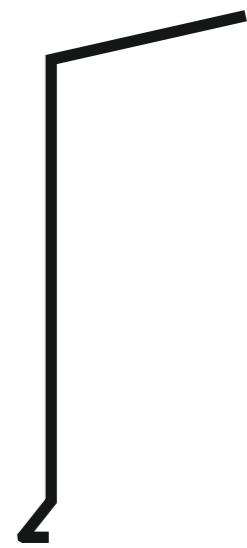

65.



66.

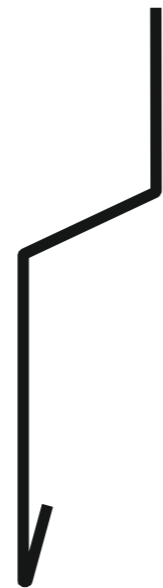

67.



68.

69.

70.

71.

72.



Kalenica dachowa
GT1

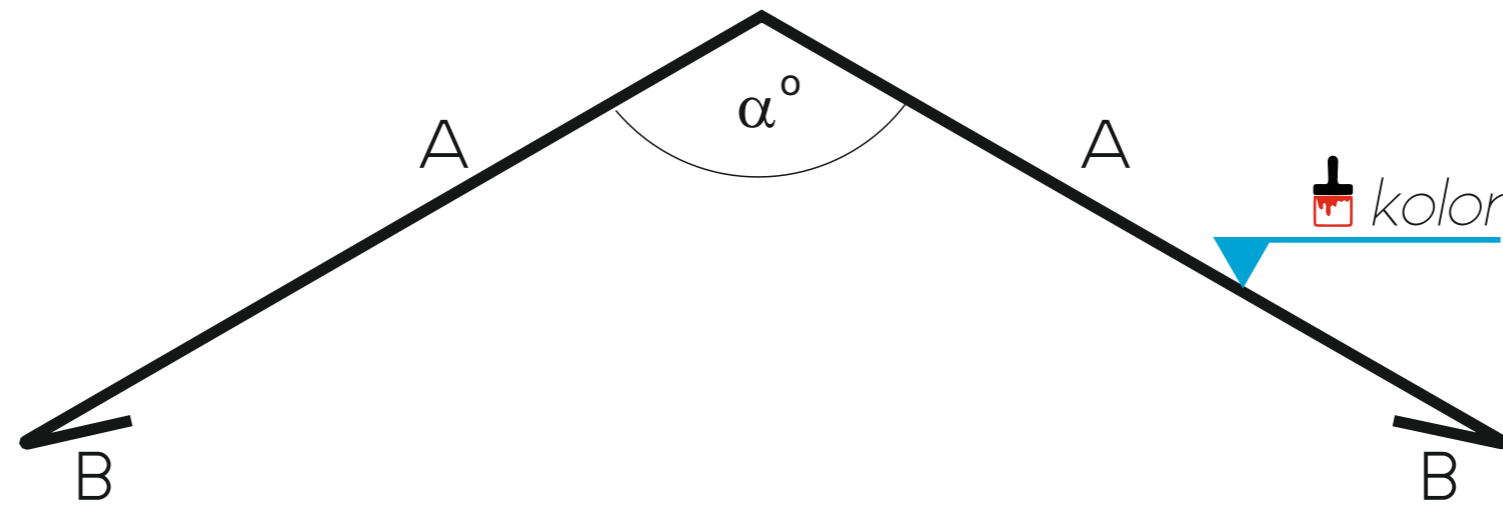

01.



100
95
75
25
5
0

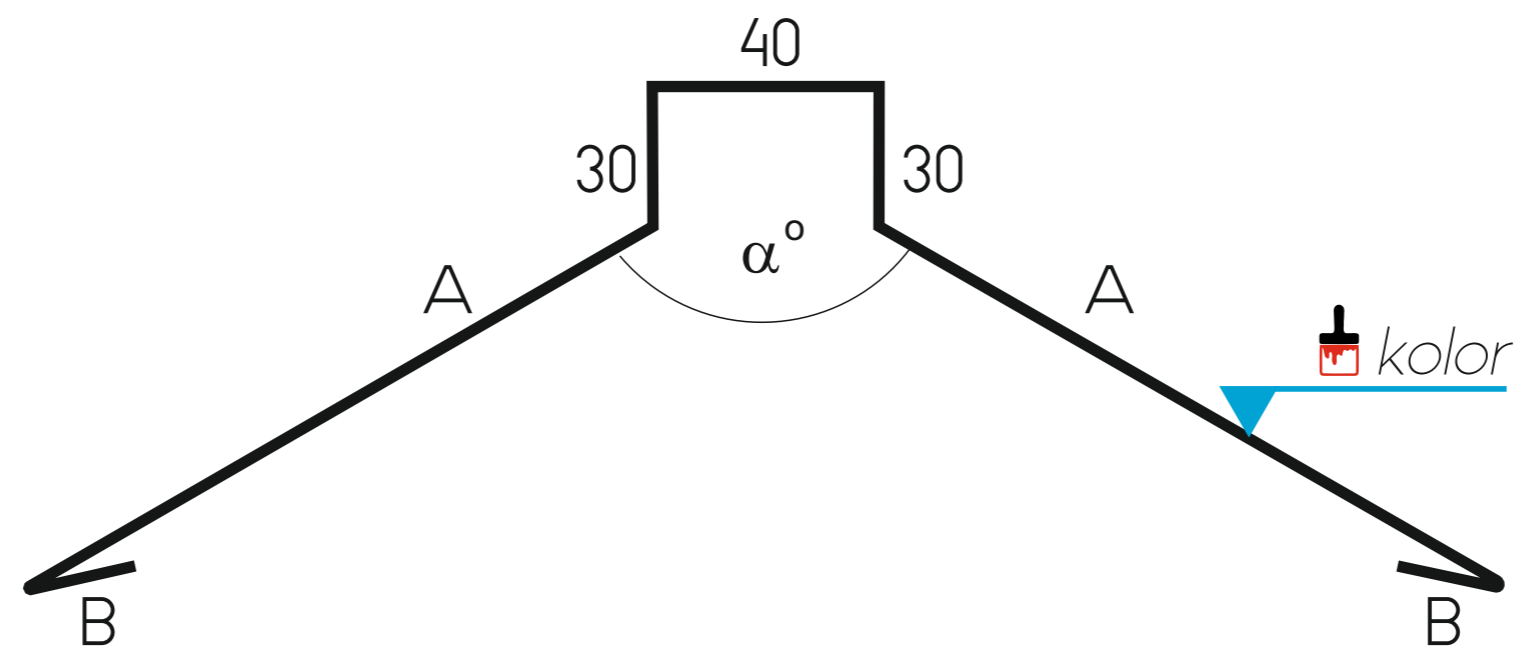

02.



Kalenica dachowa
GT3

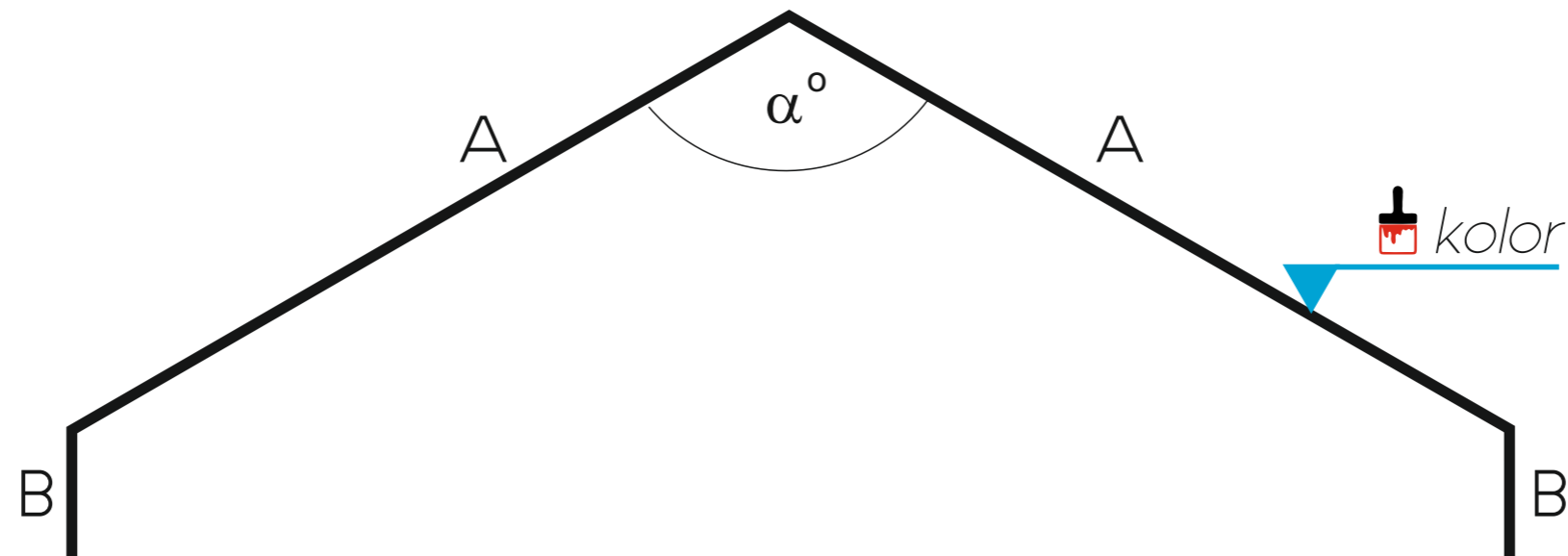

03.



100
95
75
25
5
0

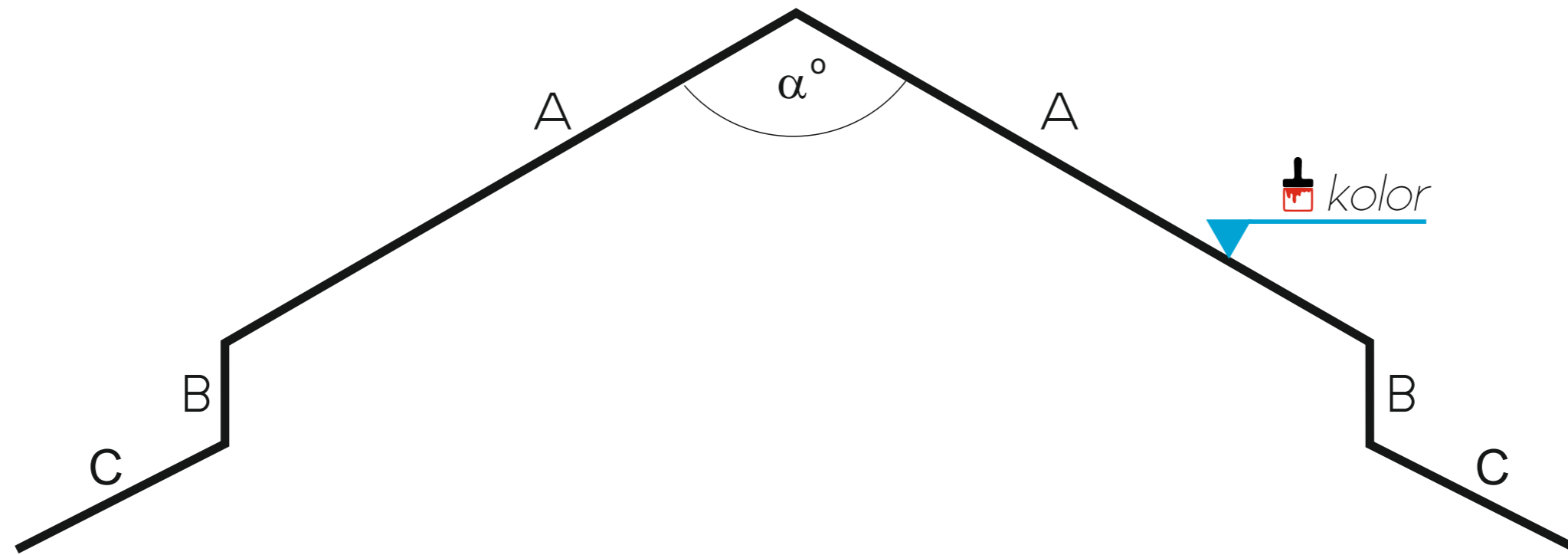

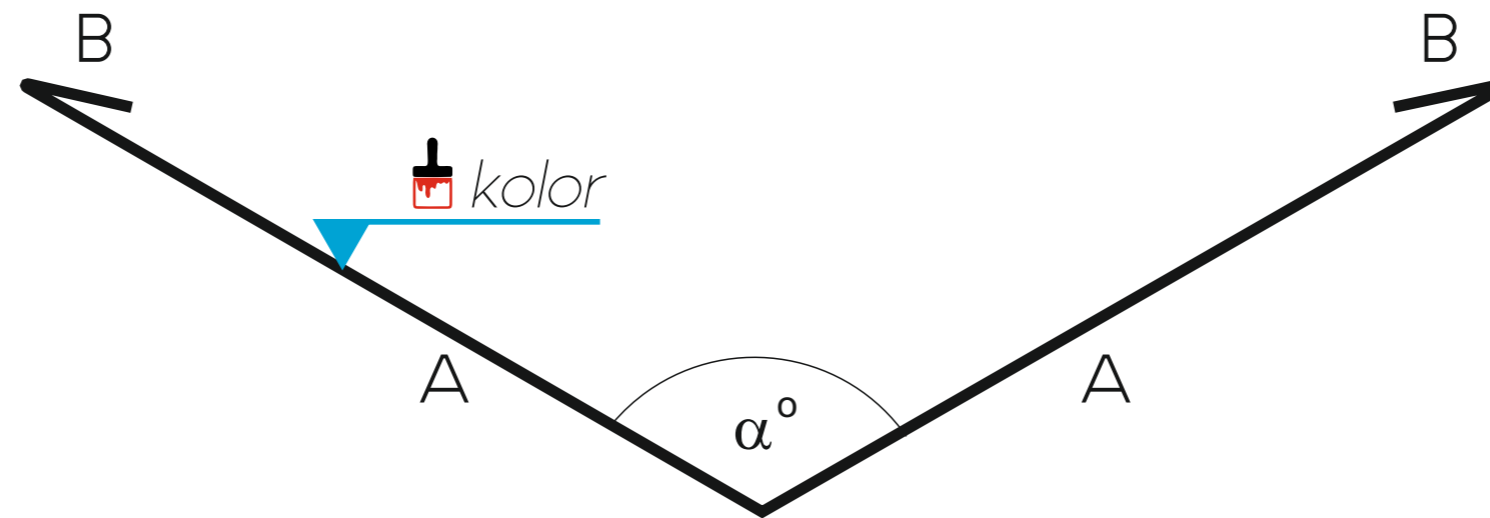

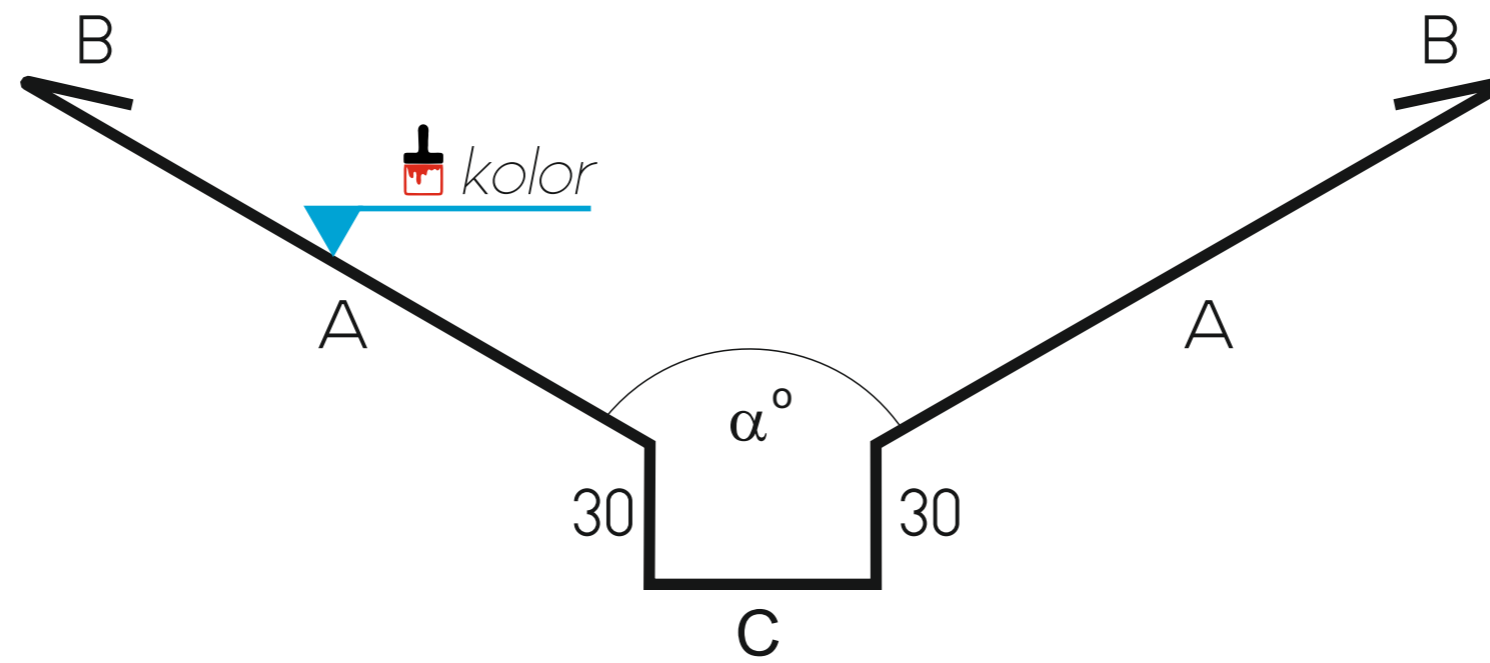

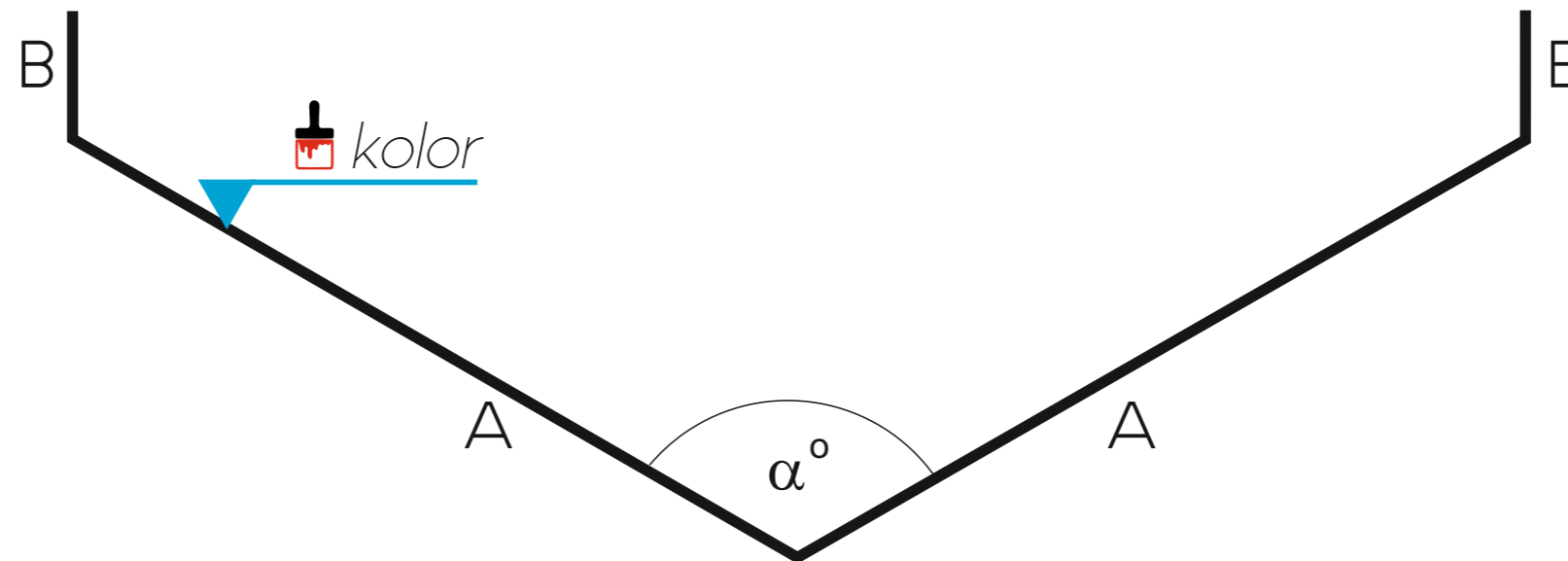



Rynna koszowa
RK4

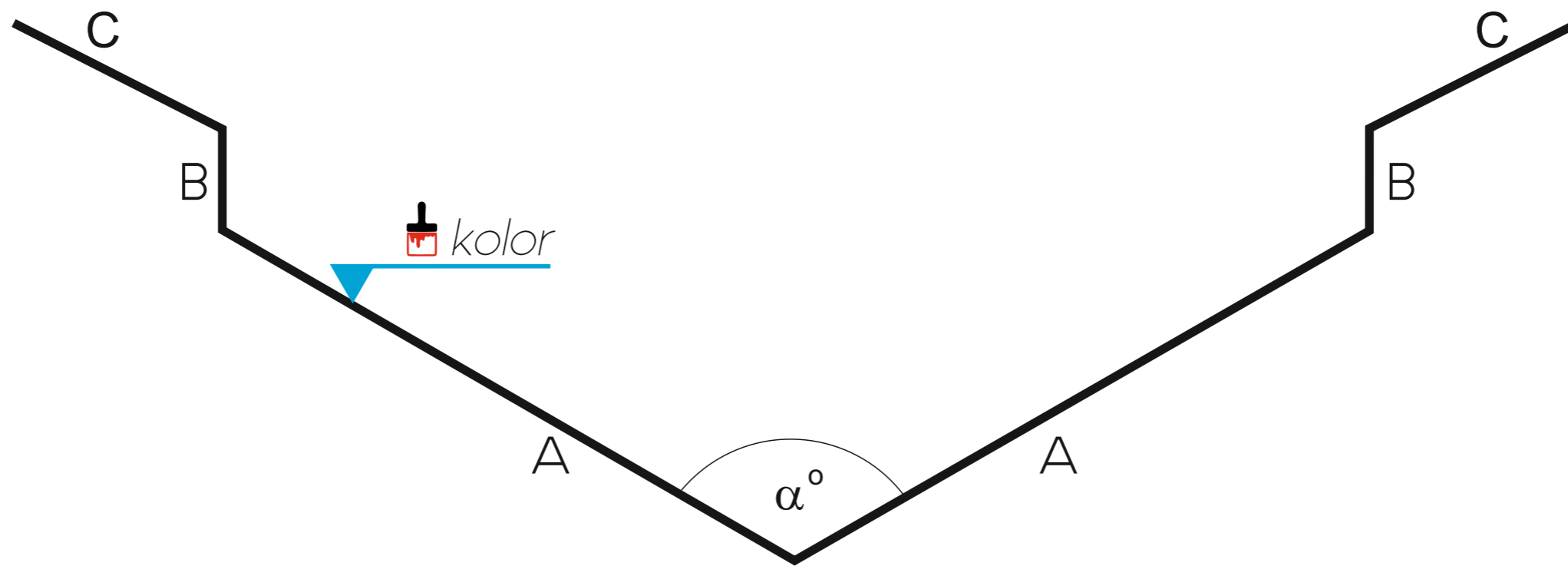

08.



100
95
75
25
5
0



Rynna koszowa

RK5

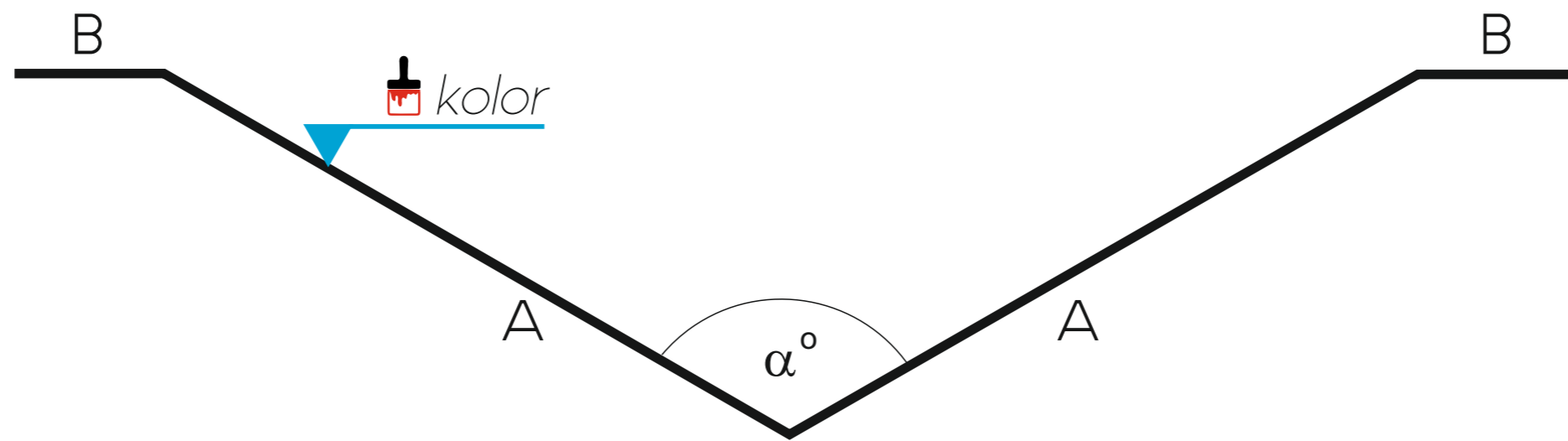

09.



100
95
75
25
5
0



Pas nadrynowy
PN1



10.



100
95
75
25
5
0



Pas nadrynowy
PN2



11.



100
95
75
25
5
0



Pas nadrynowy
PN3

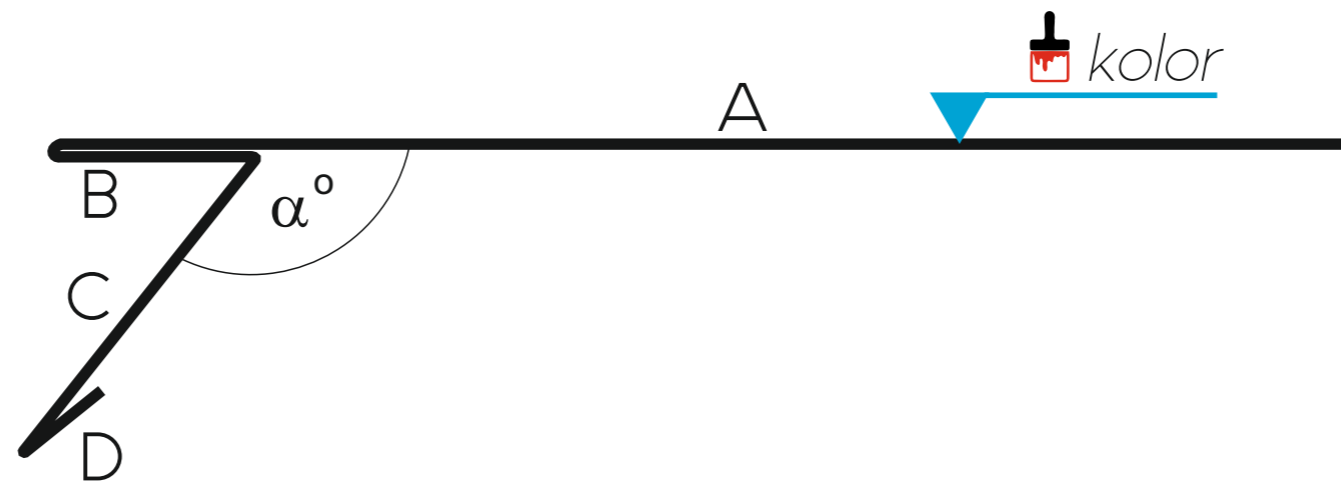

12.



100
95
75
25
5
0



Obróbka typu T
PT1

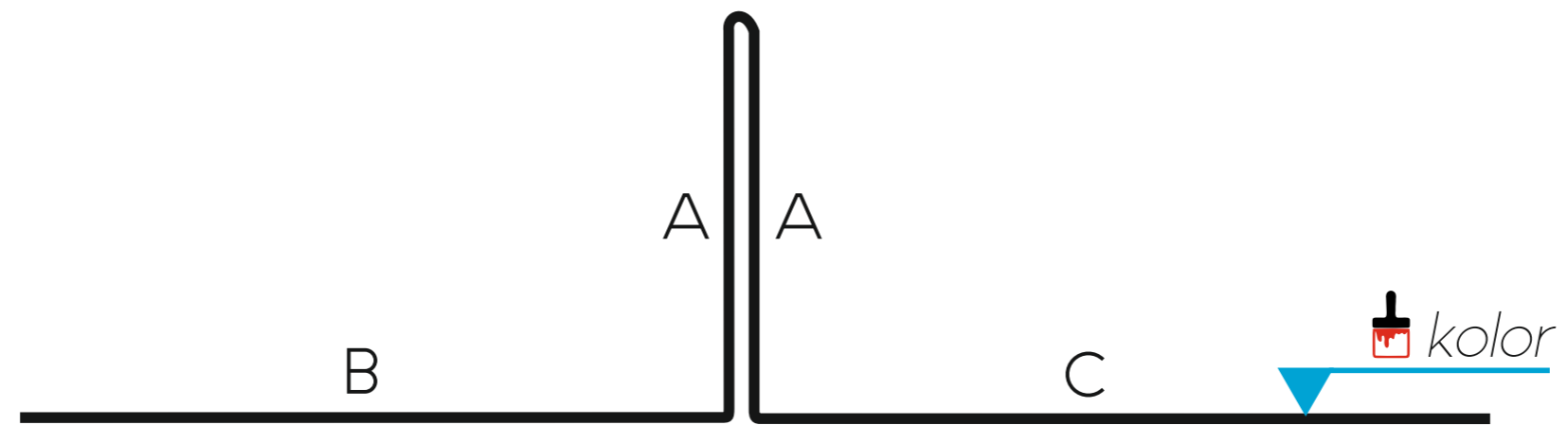

13.



100
95
75
25
5
0

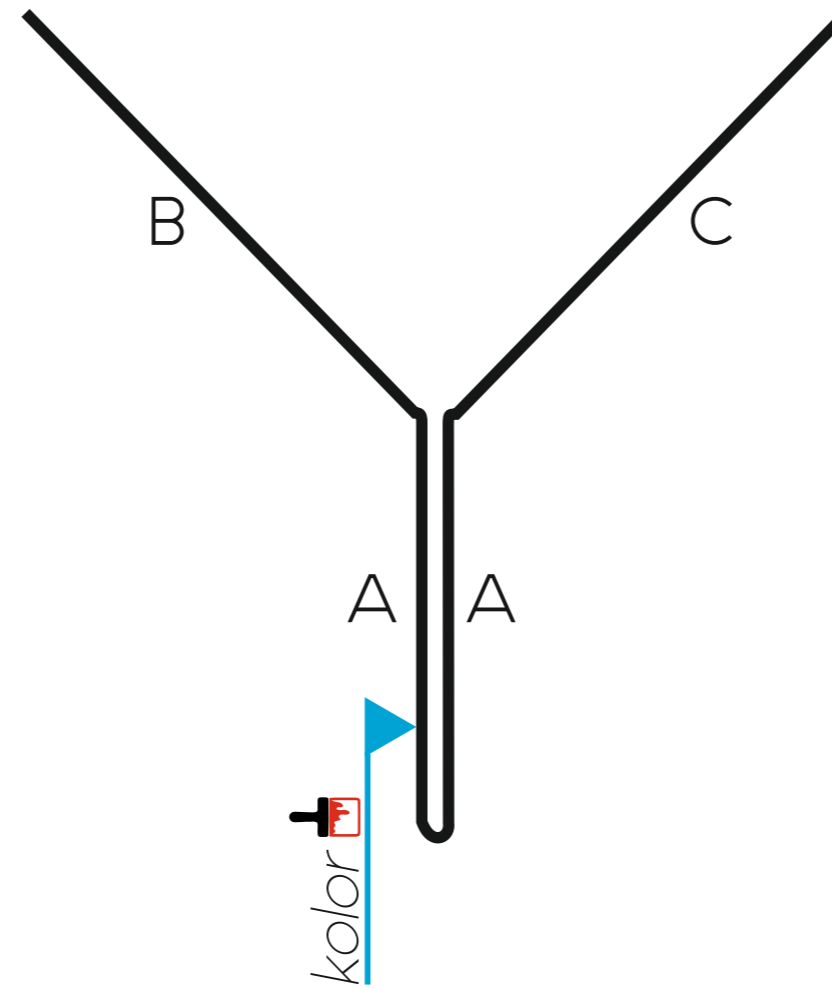



Obróbka przeciwsniegowa

PA1

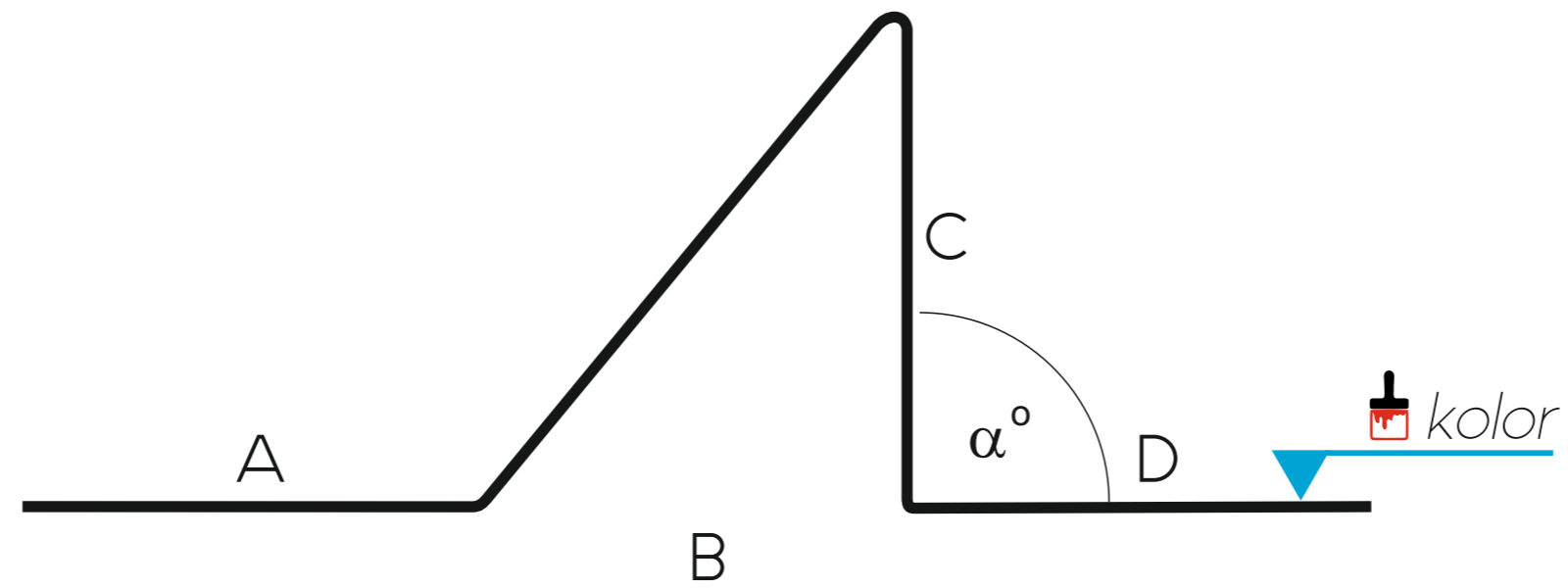

15.



100
95
75
25
5
0



Obróbka belki

OB1

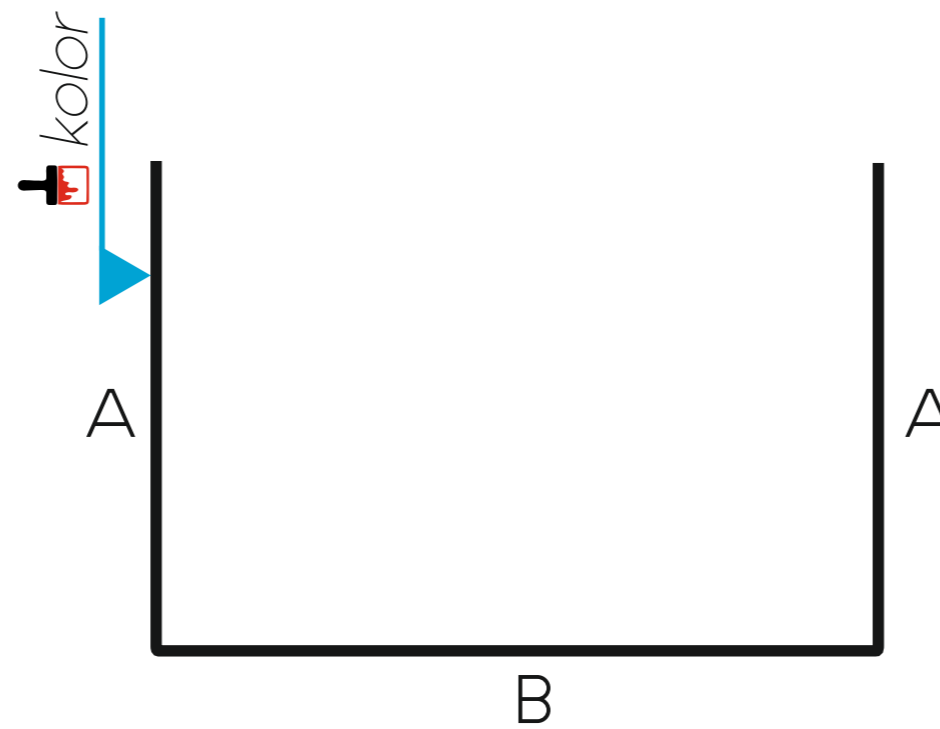

16.



100
95
75
25
5
0



Obróbka belki
OB2

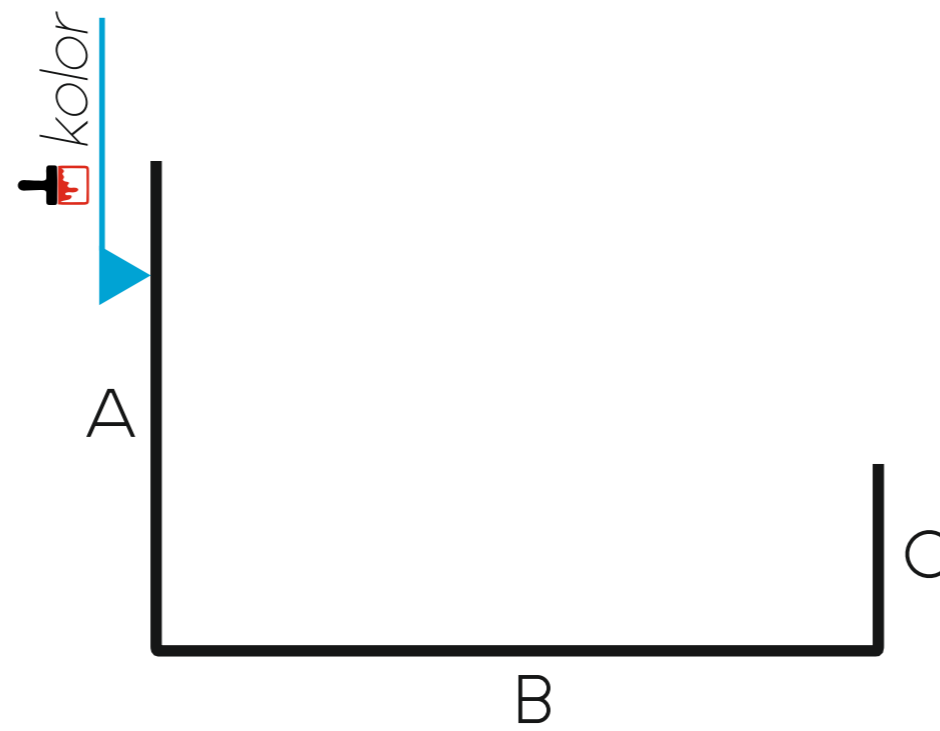

17.



100
95
75
25
5
0



Obróbka belki
OB3

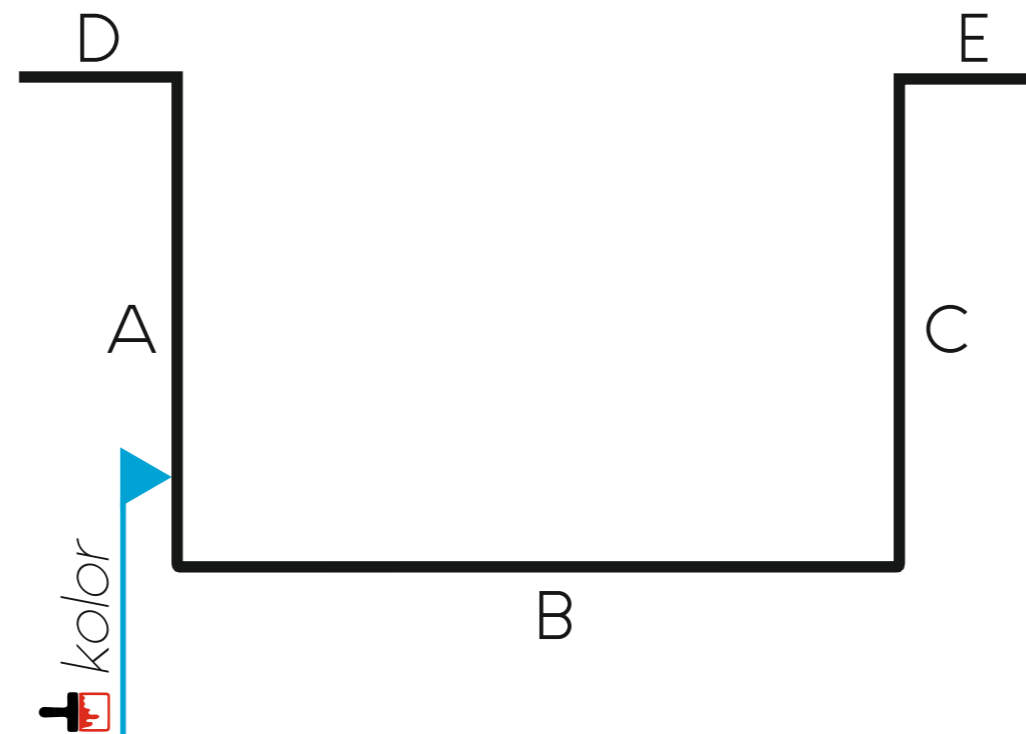

18.



100
95
75
25
5
0



Obróbka belki
OB4

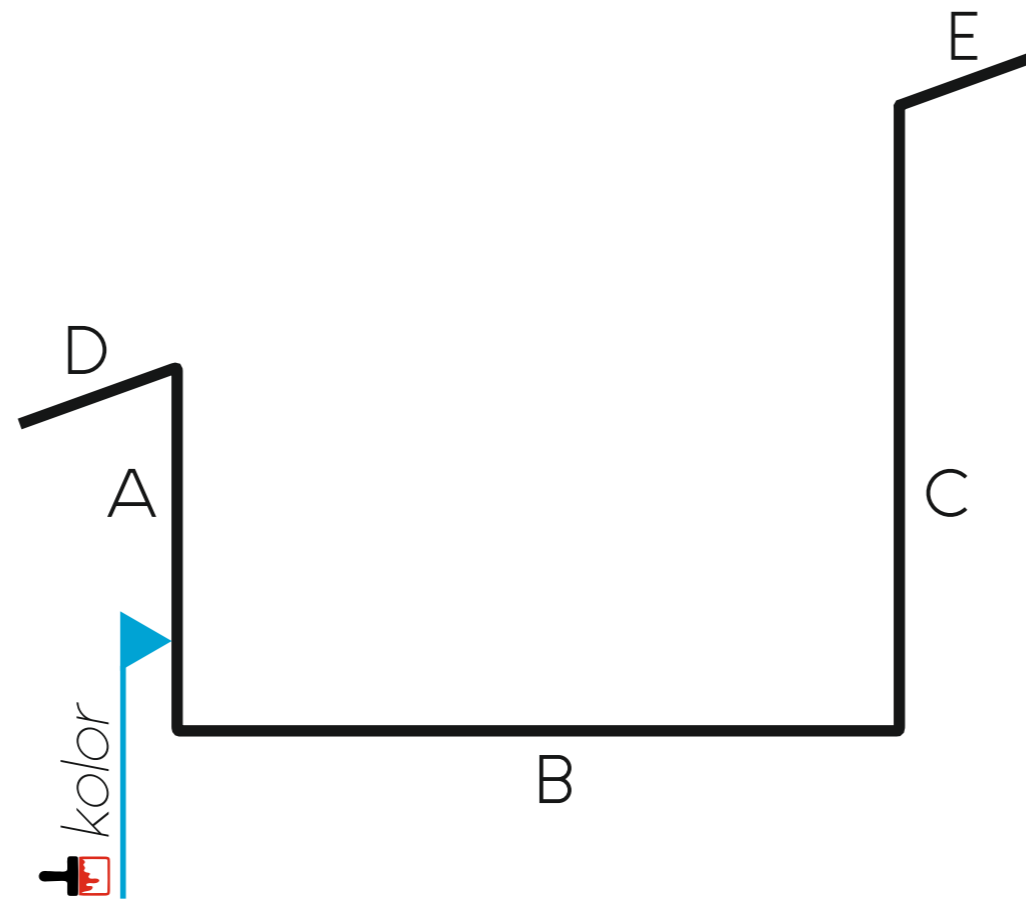

19.



100
95
75
25
5
0



Listwa kąтова
LK1

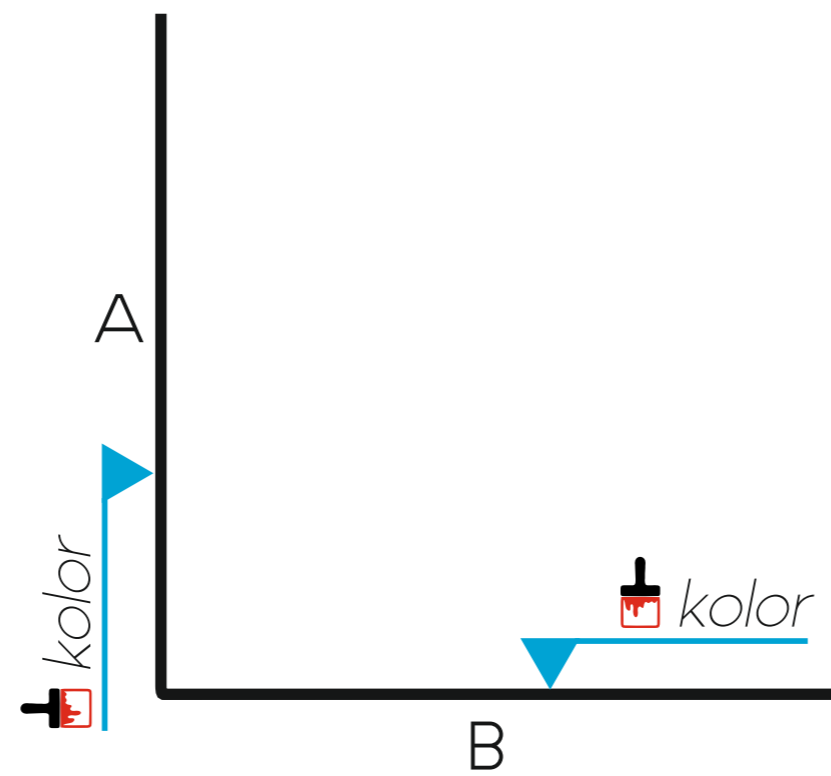

20.



100
95
75
25
5
0



Listwa kąтова
LK2

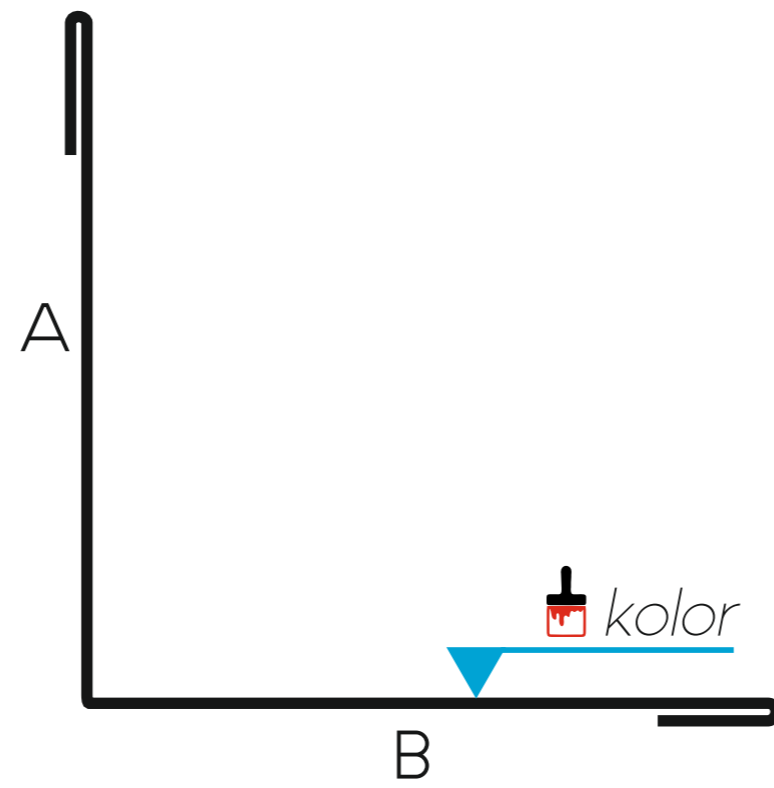

21.



100
95
75
25
5
0



Listwa kąтова
LK3

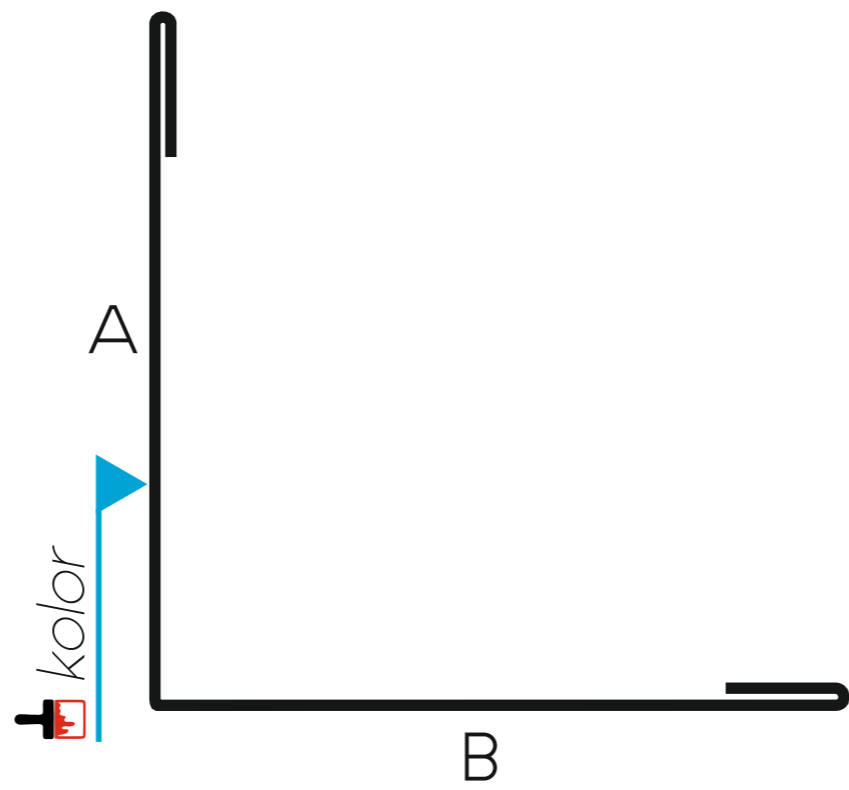

22.



100
95
75
25
5
0

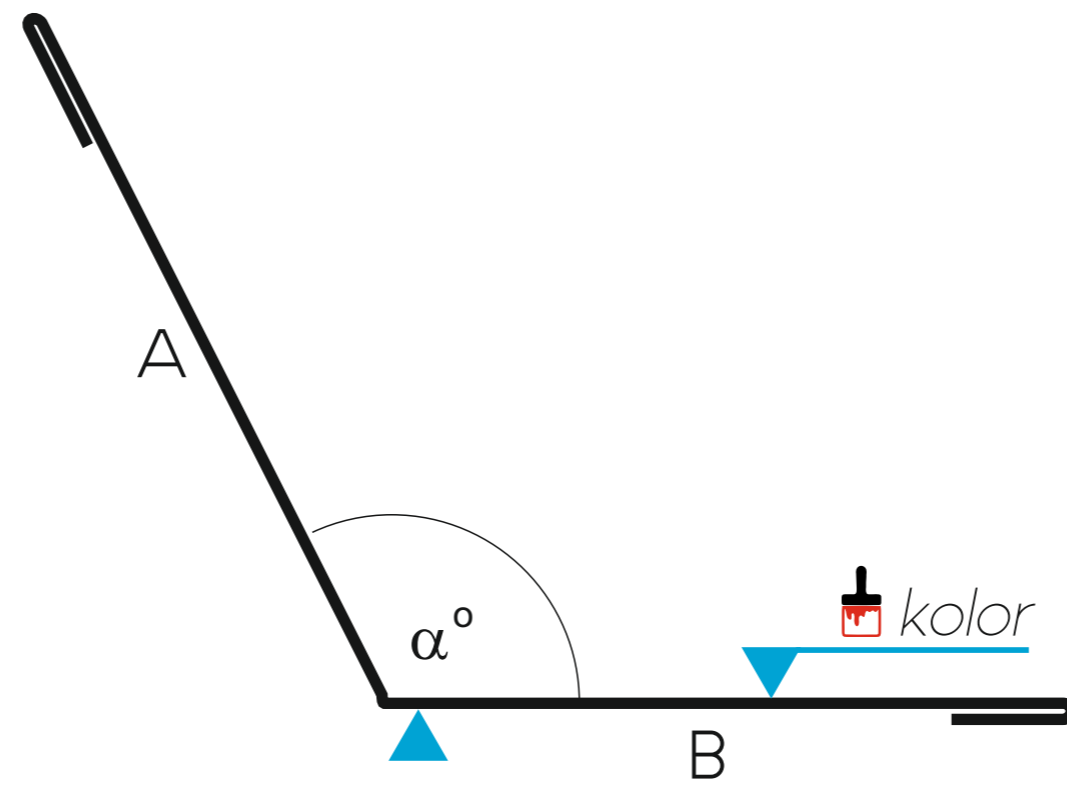

23.



Listwa kątowna
LK5

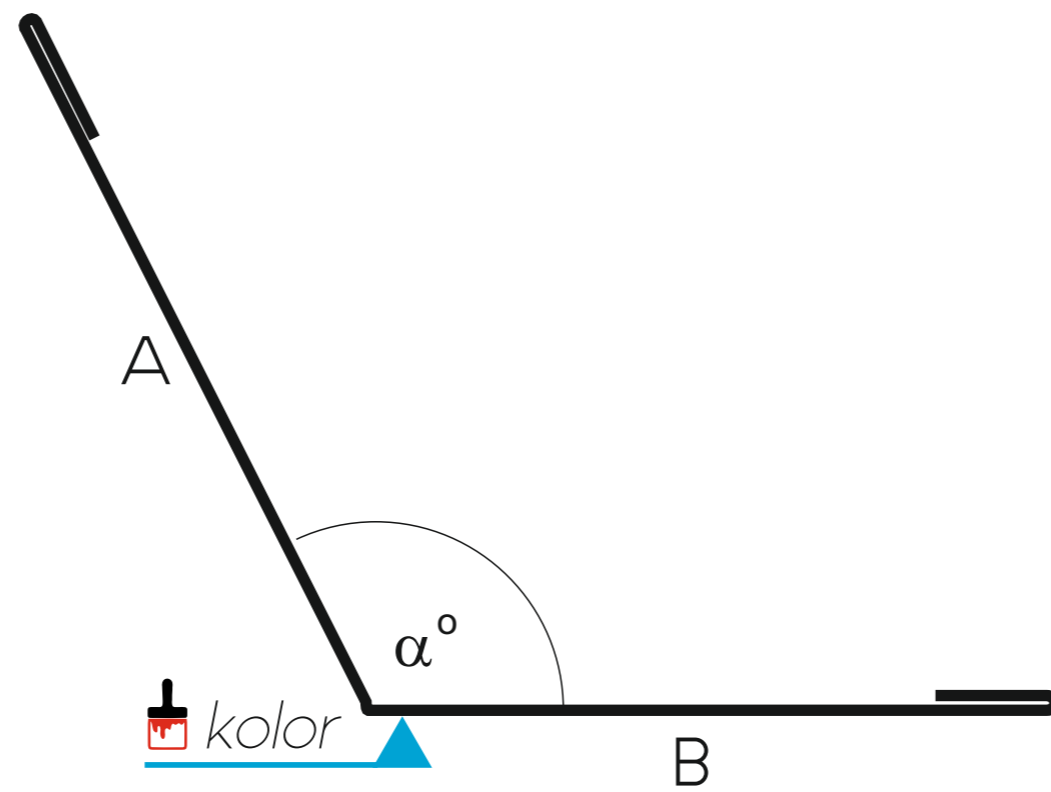

24.



100
95
75
25
5
0

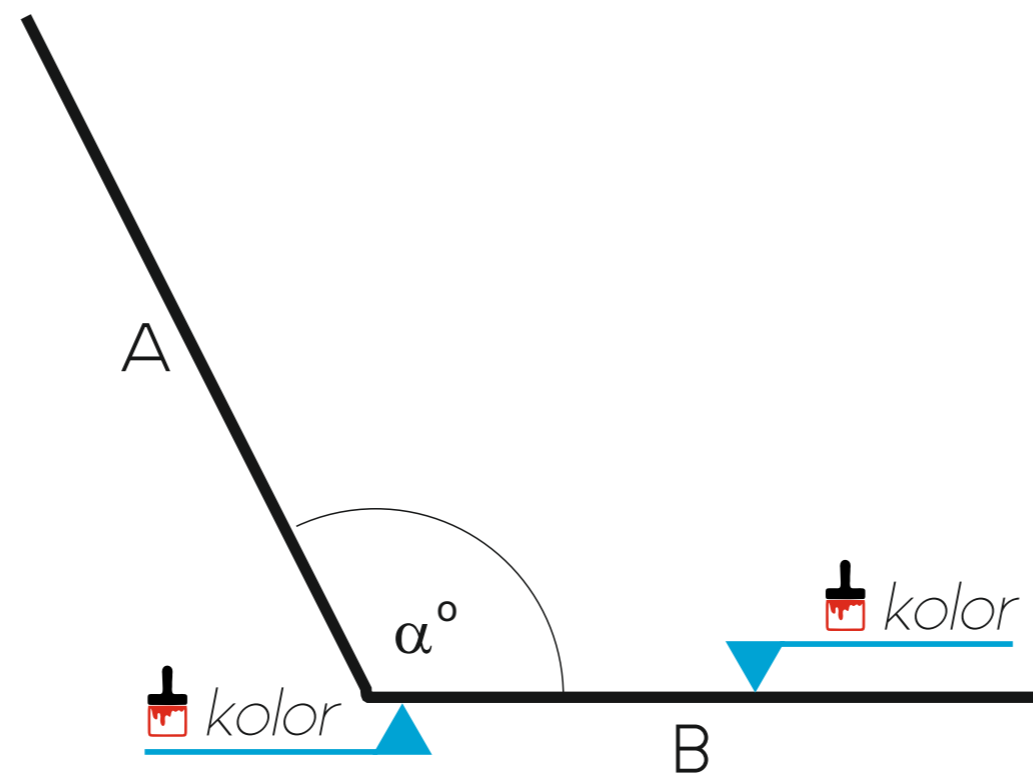

25.

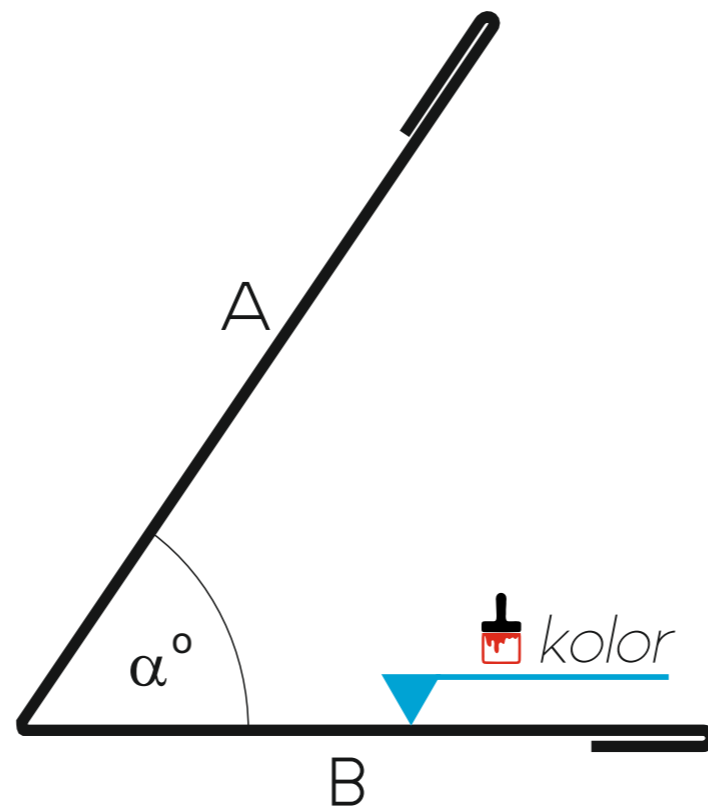



Listwa maskująca

LP1



27.



100
95
75
25
5
0



Listwa maskująca
LP2

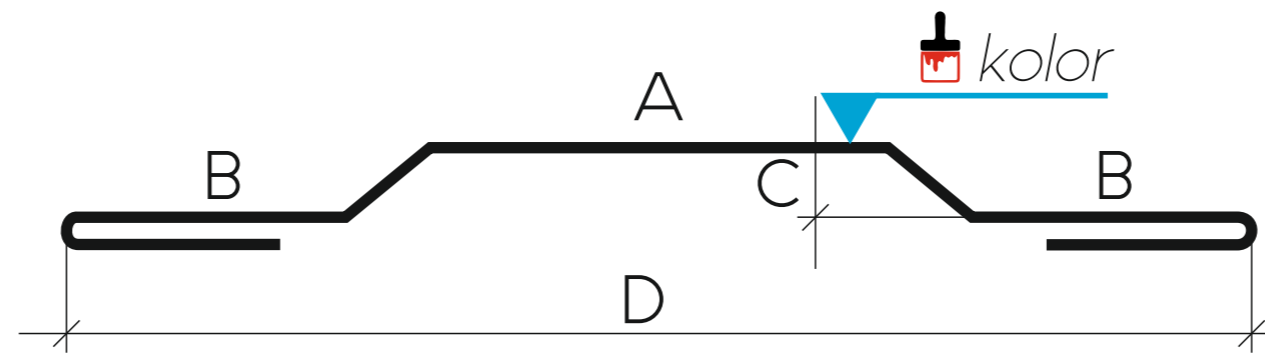

28.



100
95
75
25
5
0



Listwa maskująca
LP3



29.



100
95
75
25
5
0



Listwa maskująca

LP4



30.



100
95
75
25
5
0



Obróbka ogniomuru
MR1

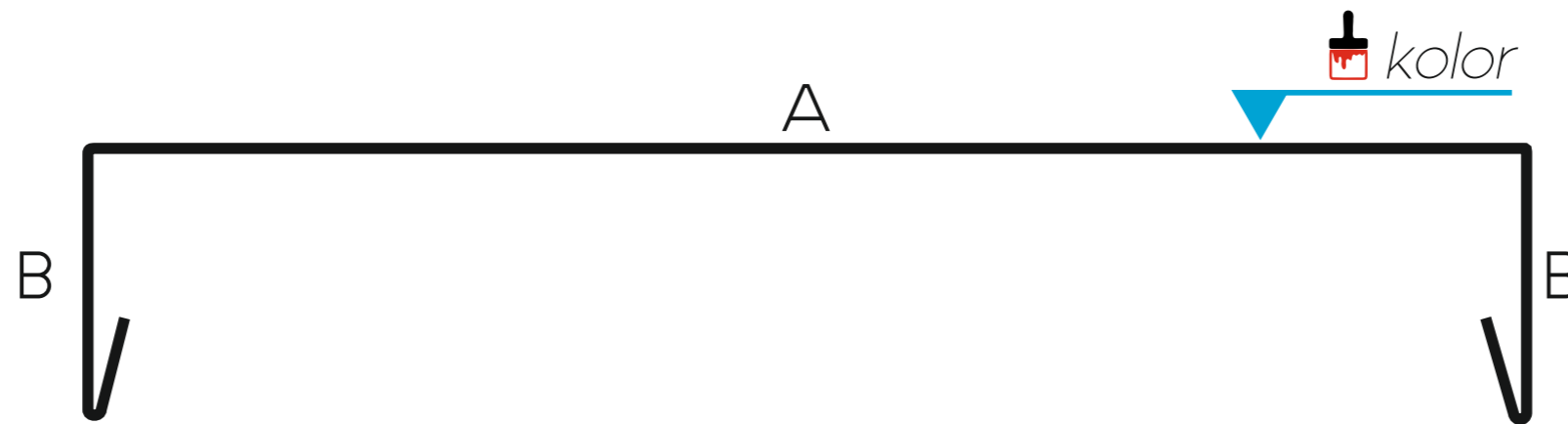

31.



100
95
75
25
5
0



Parapet okienny
PR1

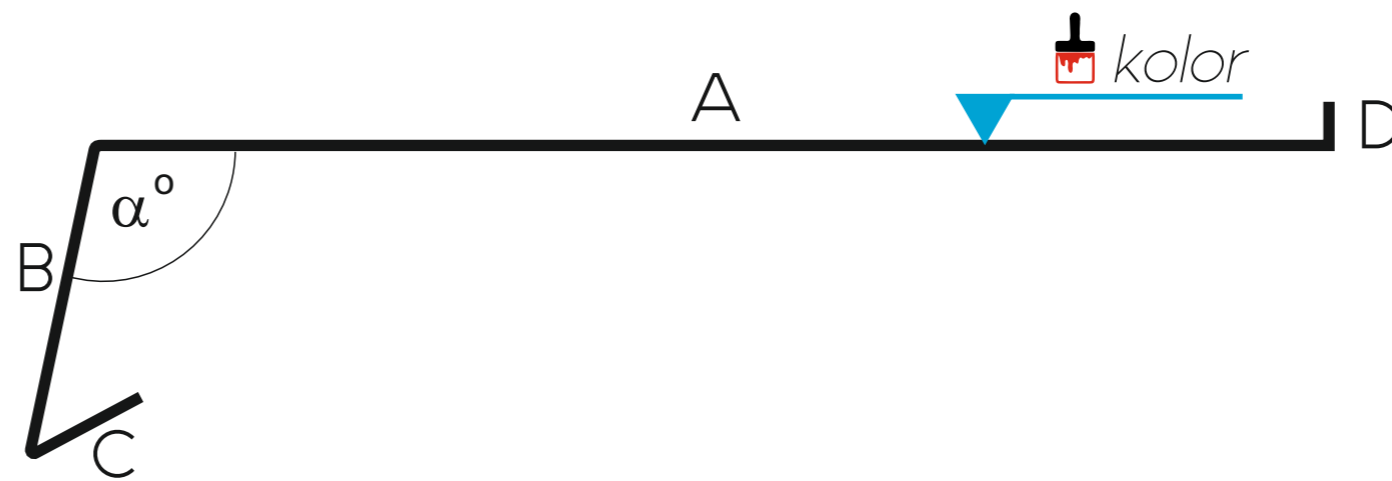

32.



100
95
75
25
5
0



Parapet okienny
PR2

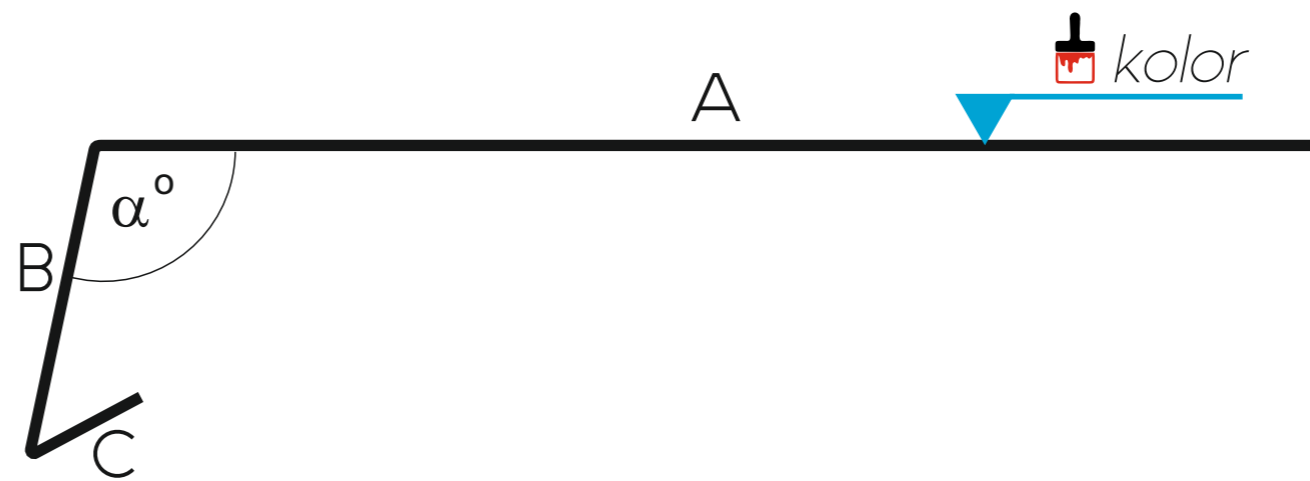

33.



100
95
75
25
5
0

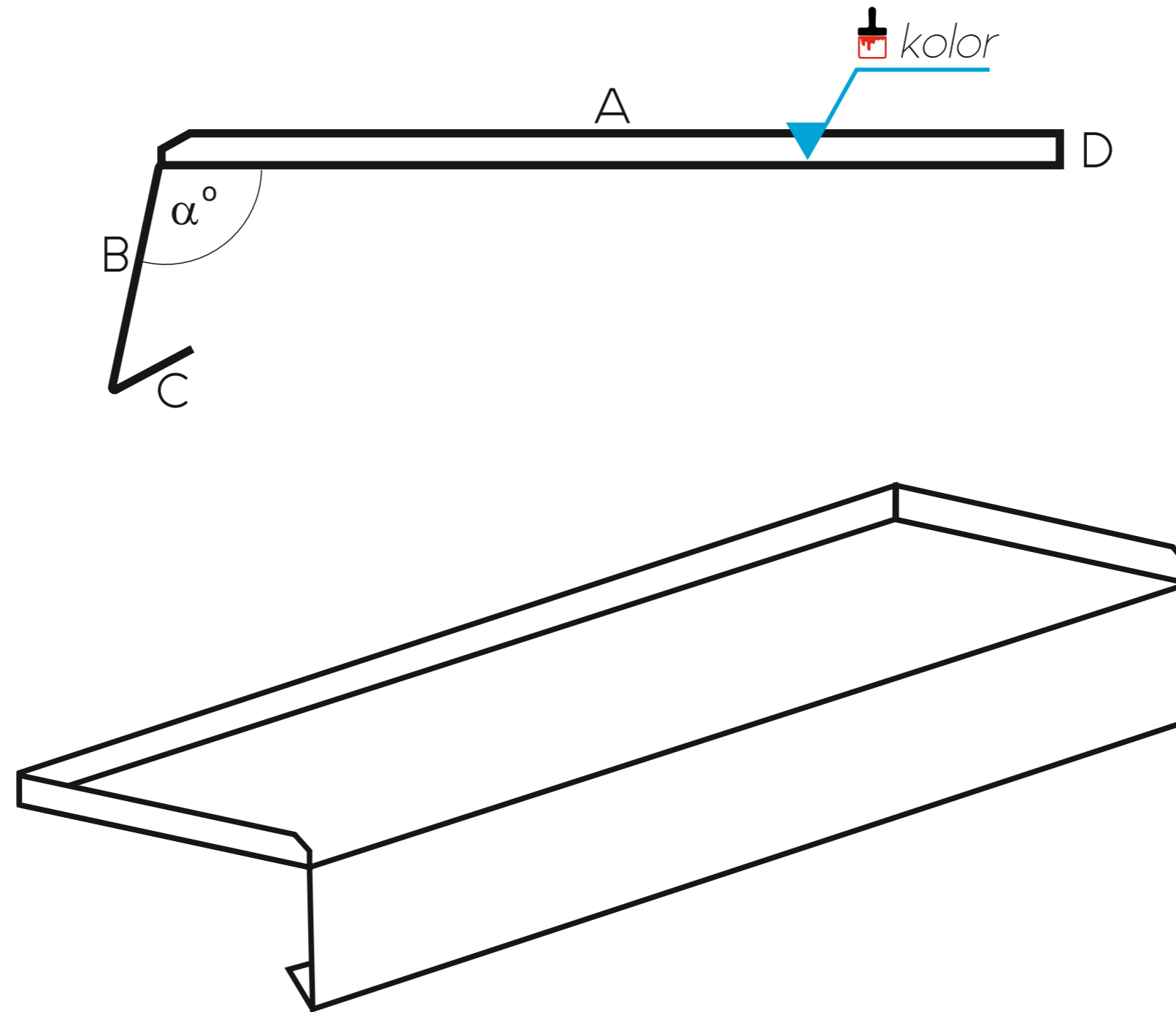

34.



Wiatrownice / koryto
odwadniająca

W7

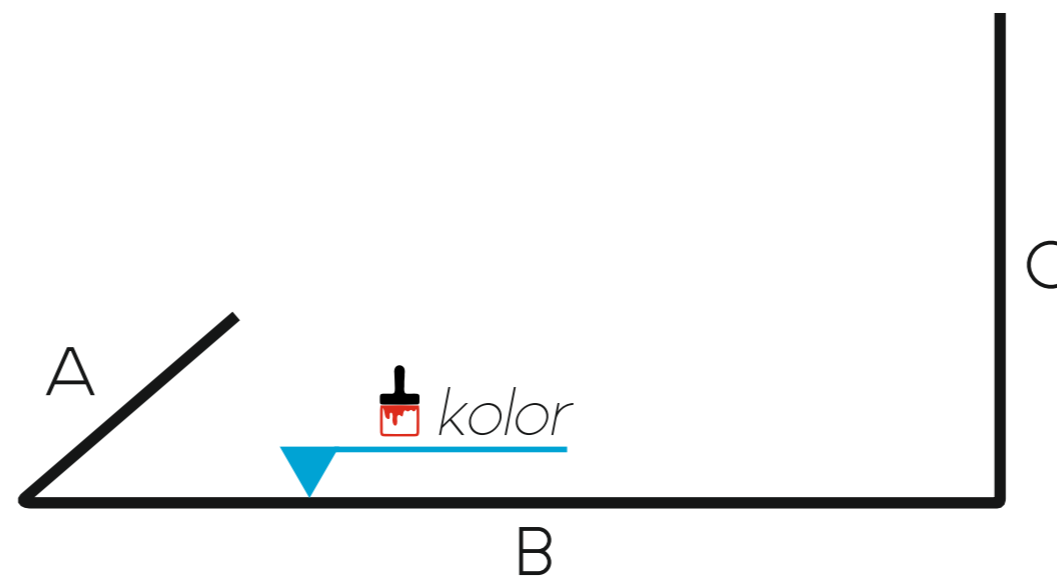

35.



100
95
75
25
5
0



Wiatrownica z korytem
odwadniającym

W1

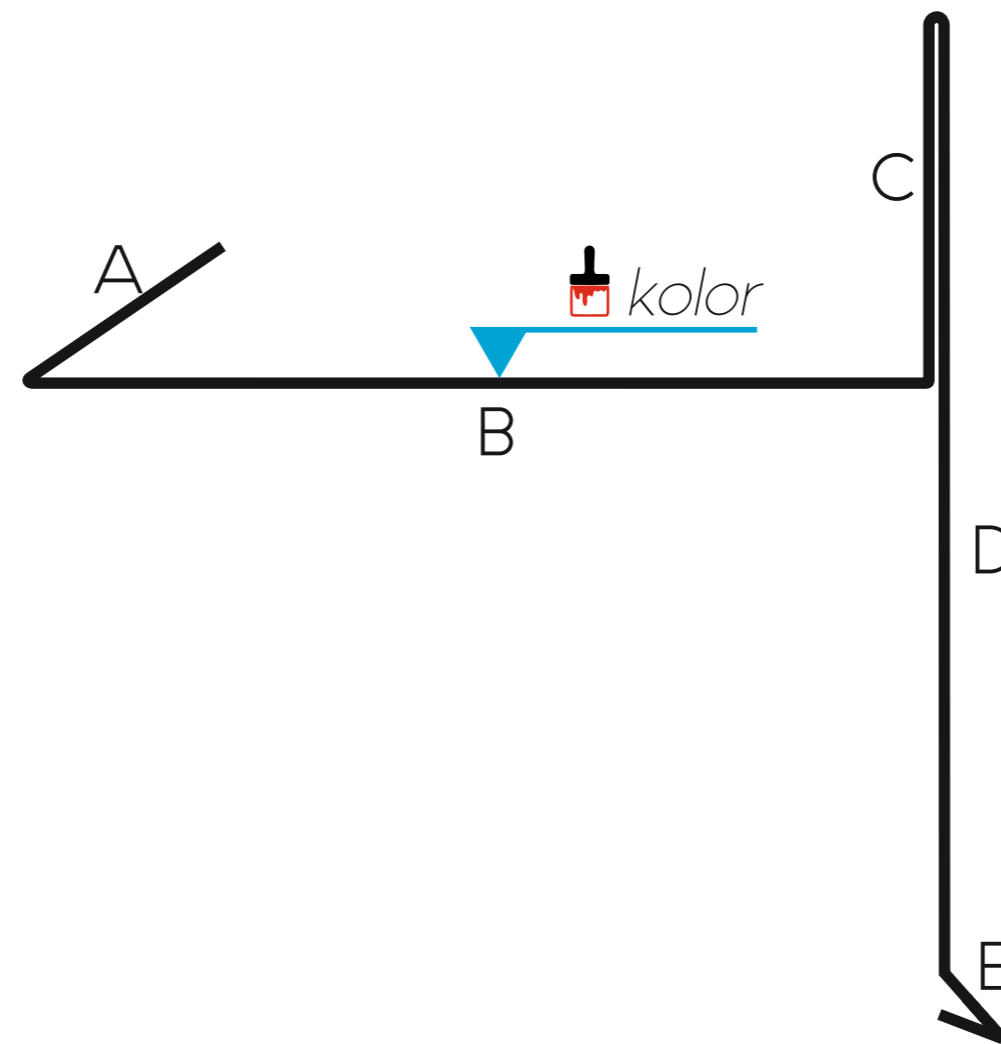

36.



100
95
75
25
5
0



Wiatrownica nakładana
na pokrycie dachowe

W2

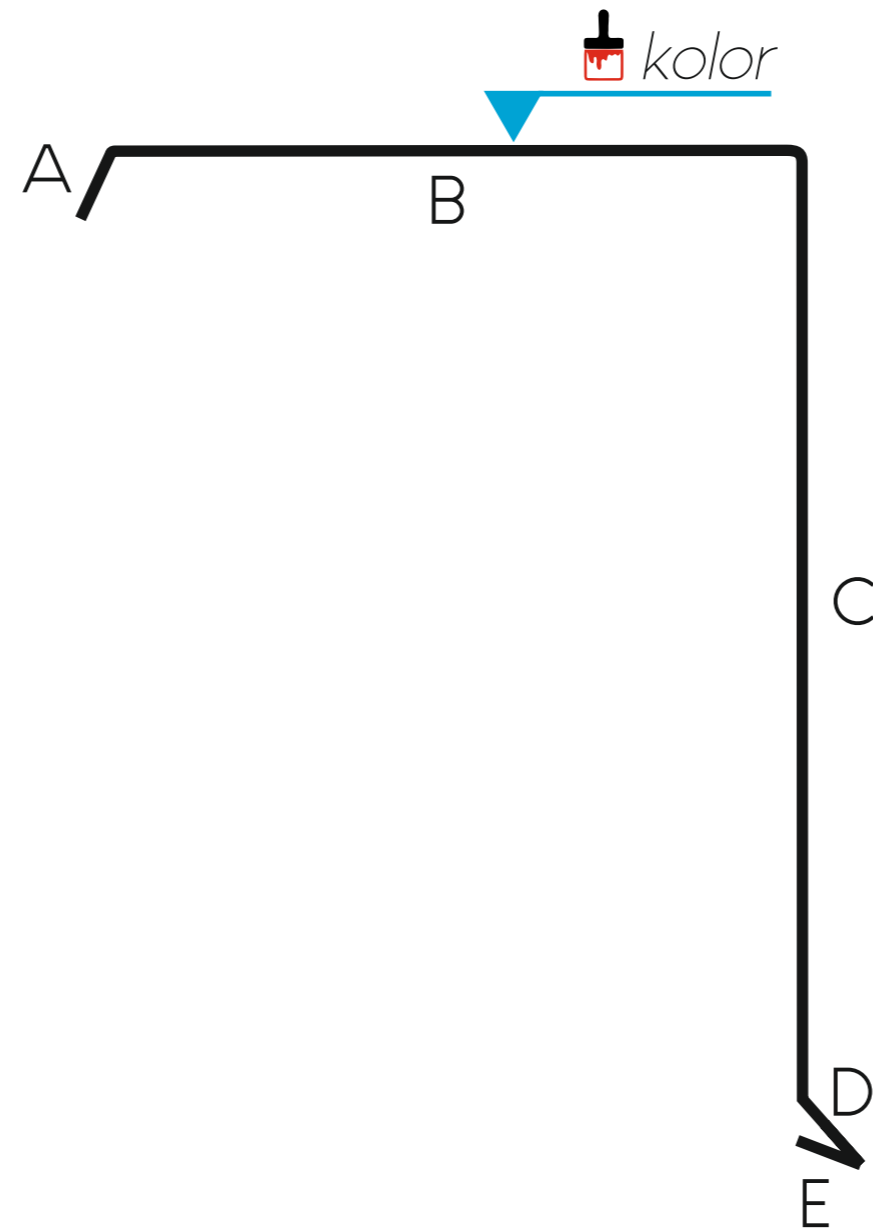

37.



100
95
75
25
5
0



Wiatrownica nakładana
na koryto odwadniające

W3

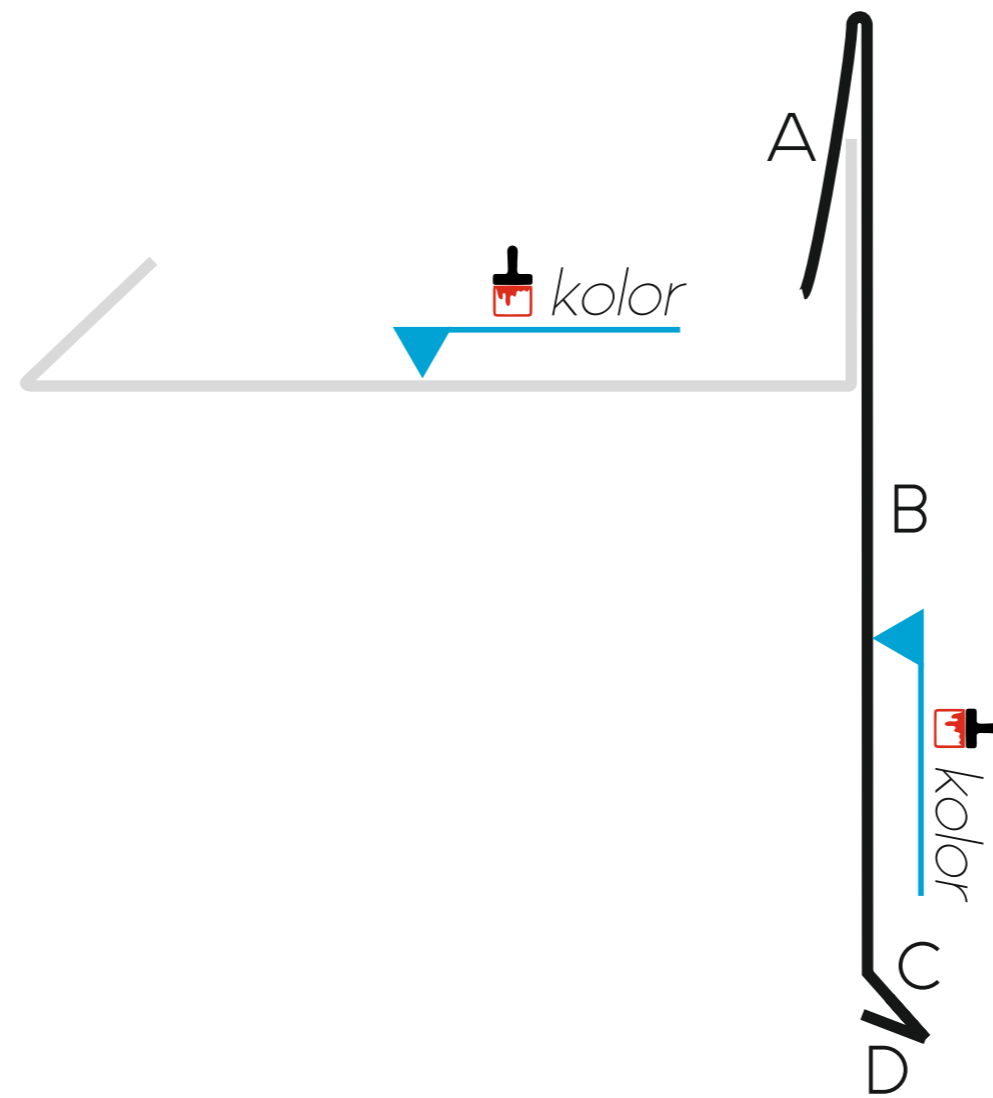

38.



100
95
75
25
5
0



Wiatrownica nakładana
na koryto odwadniające

W4

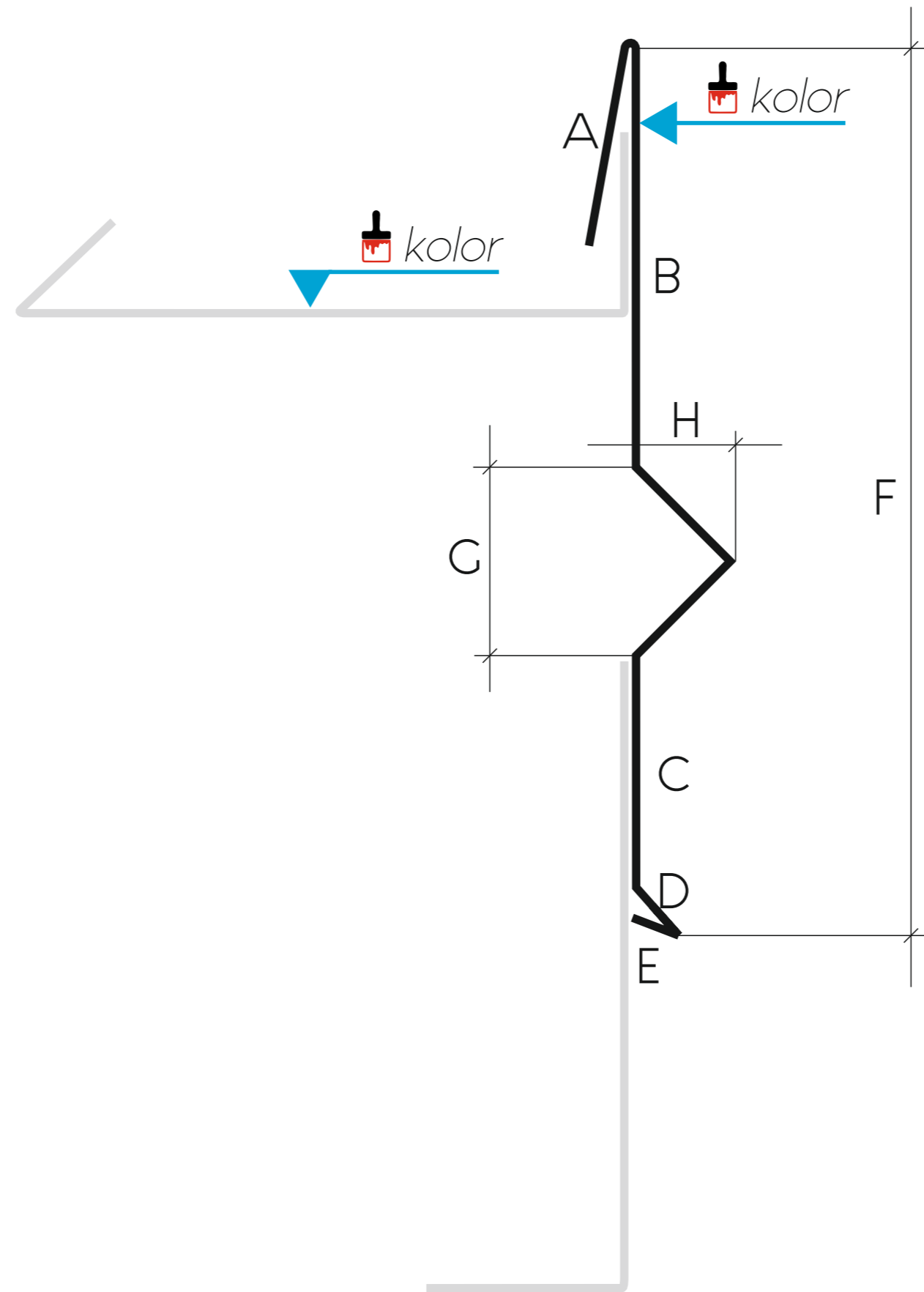

39.



100
95
75
25
5
0



Wiatrownica z korytem
płaskim do papy

W5

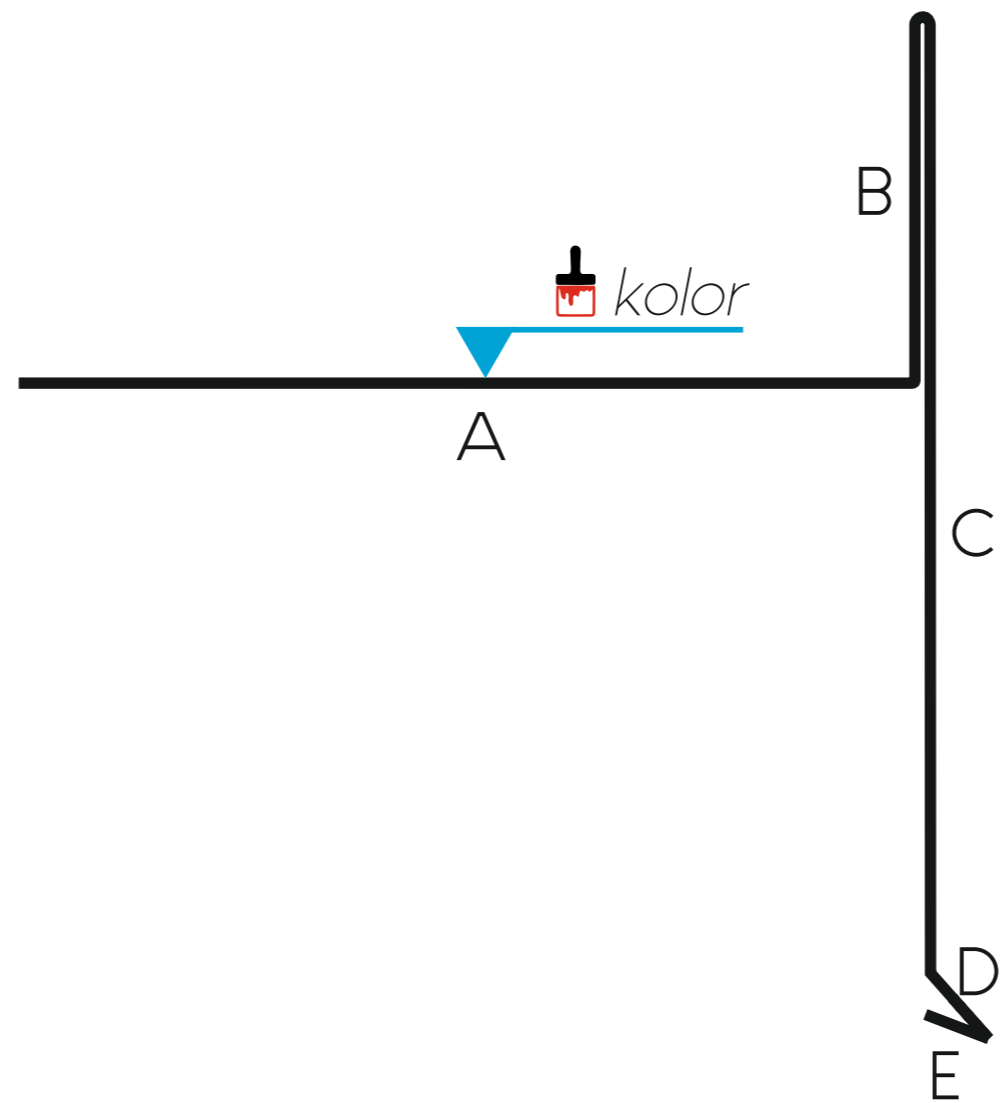

40.



100
95
75
25
5
0



Wiatrownica nakładana
na pokrycie dachowe

W6

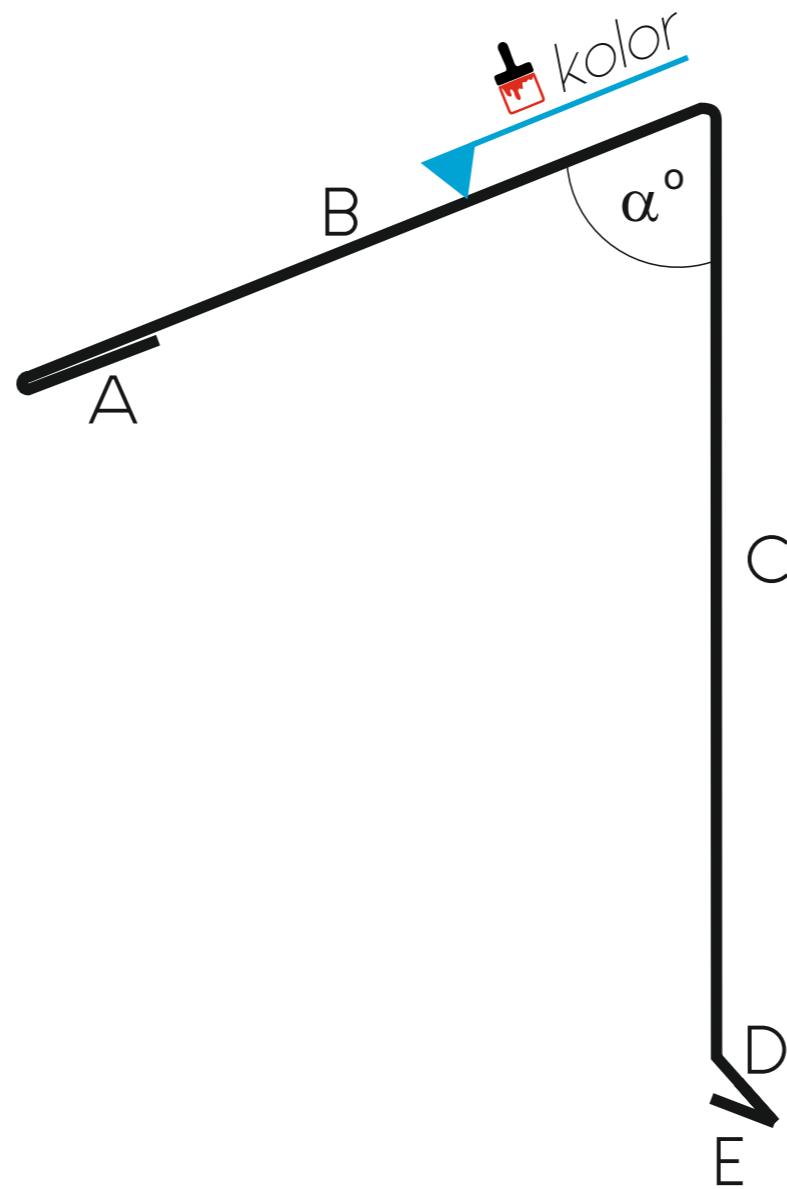

41.



100
95
75
25
5
0



Obróbka kominowa
górna

OKG1

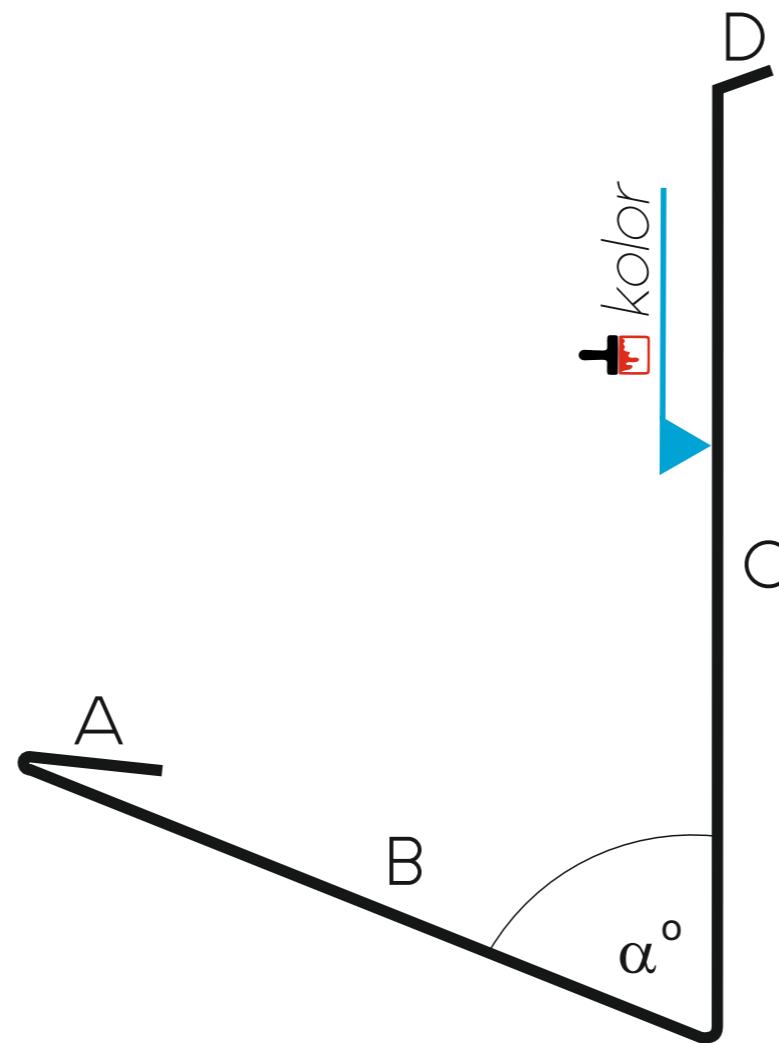

42.



100
95
75
25
5
0



Obróbka kominowa
górna

OKG2

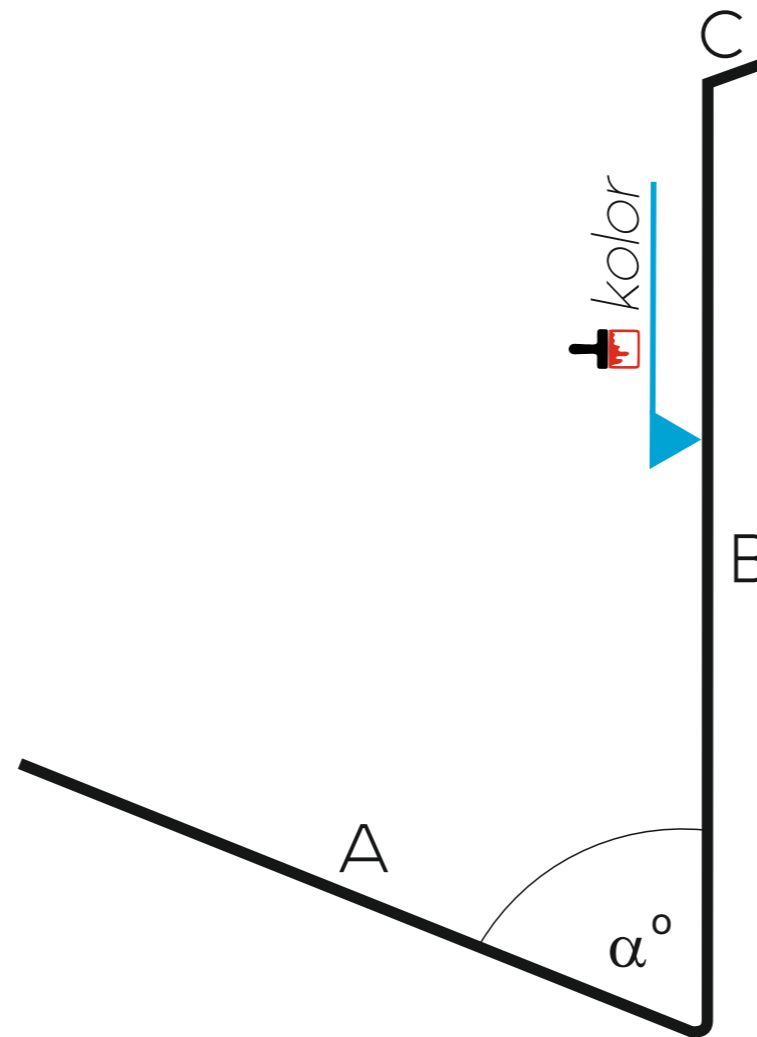

43.



100
95
75
25
5
0



Obróbka kominowa
dolna

OKD1

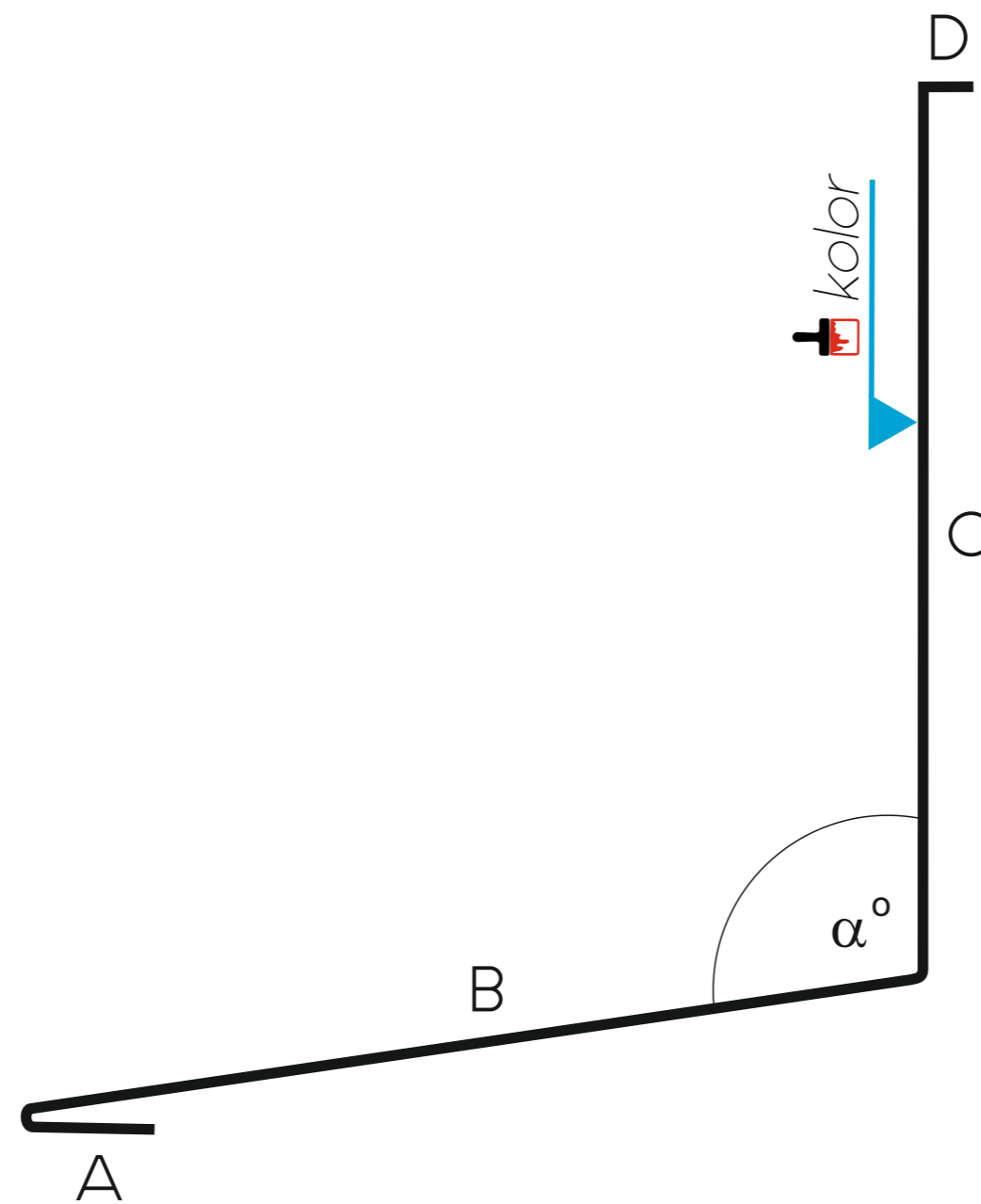

44.



100
95
75
25
5
0



Obróbka kominowa
dolna

OKD2

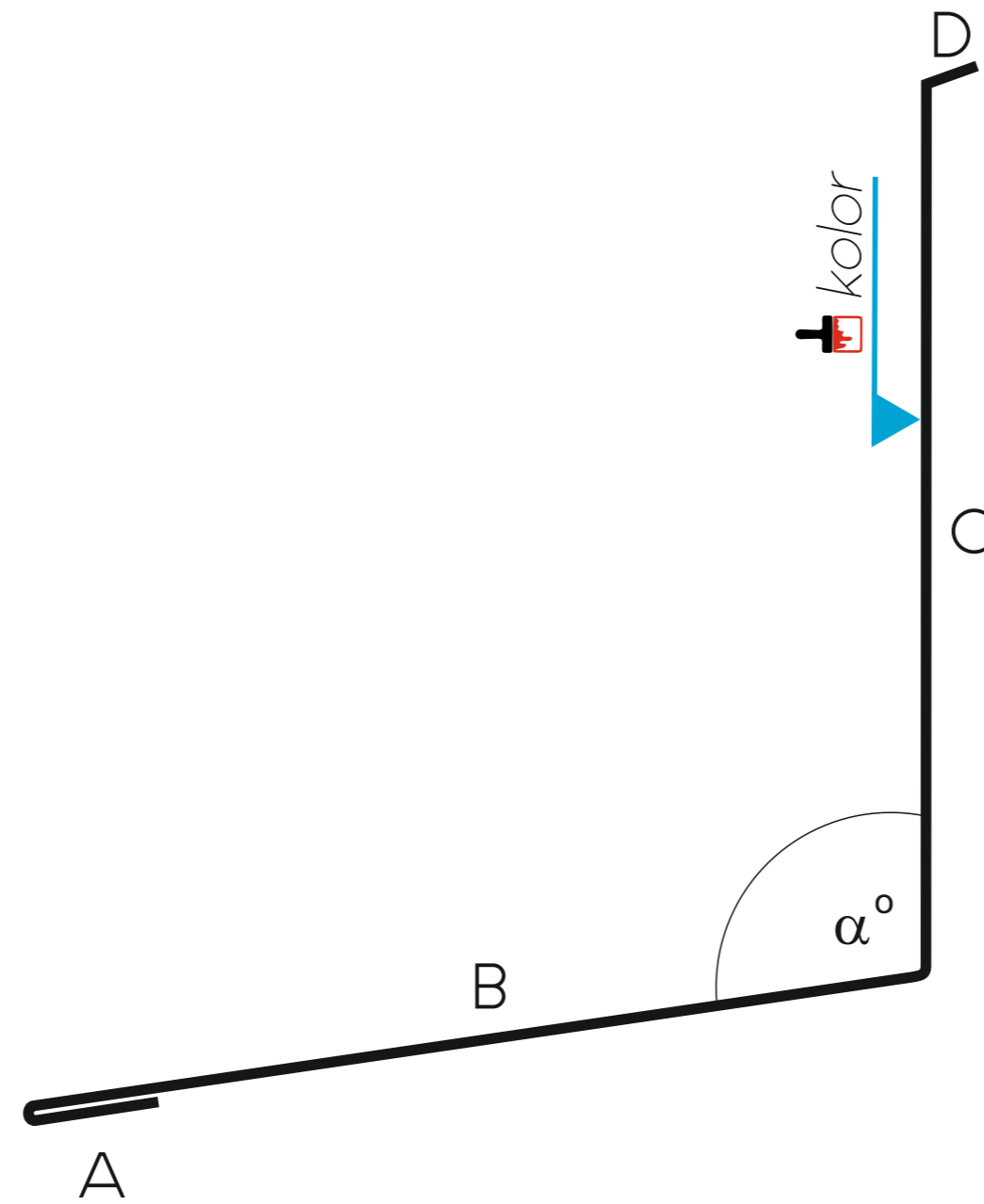

45.



100
95
75
25
5
0



Obróbka kominowa
boczna

OKB1

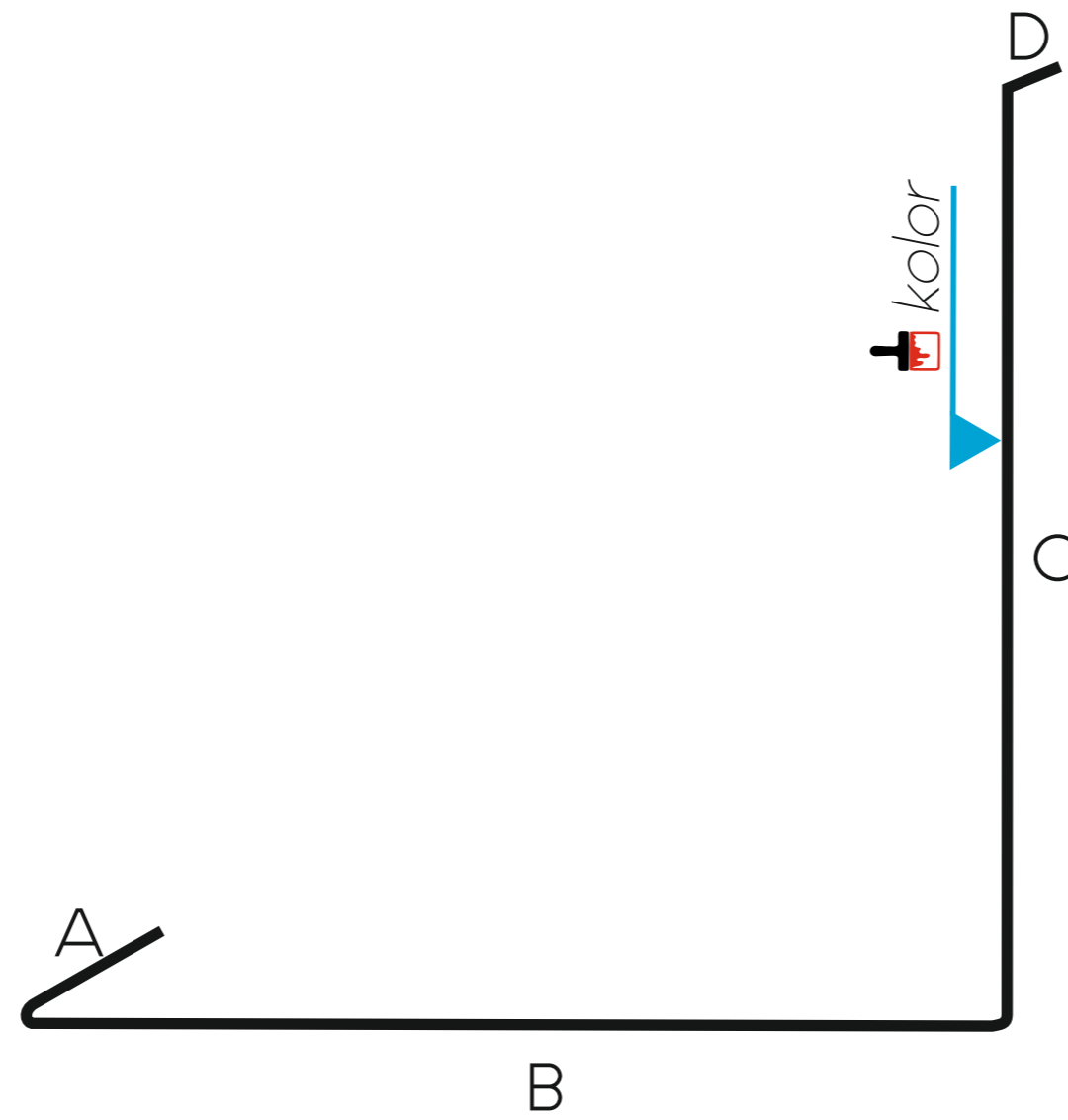

46.



100
95
75
25
5
0



Obróbka kominowa
boczna nakładana

OKB2

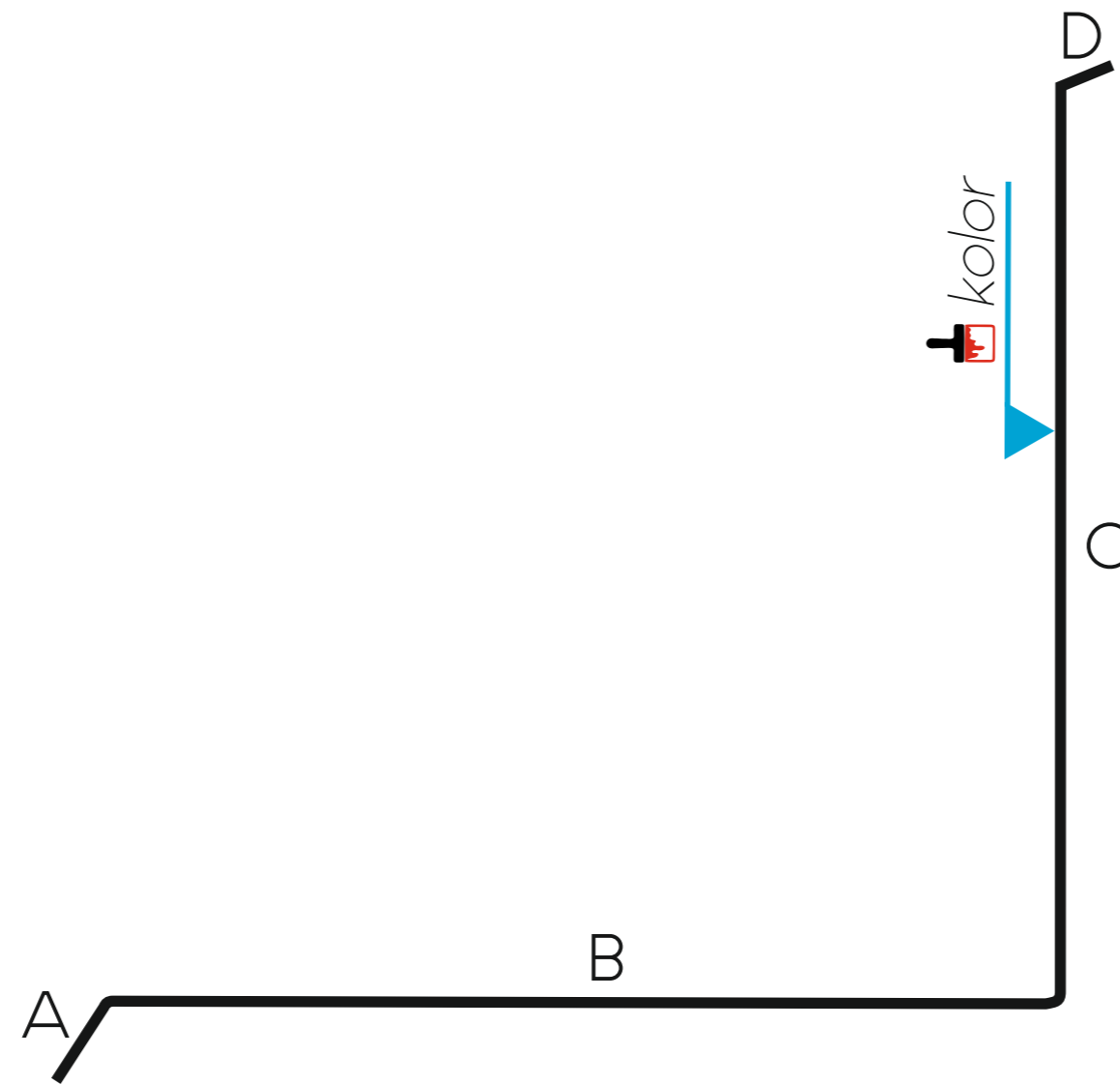

47.



100
95
75
25
5
0



Obróbka kominowa
listwa płaska

OKL1

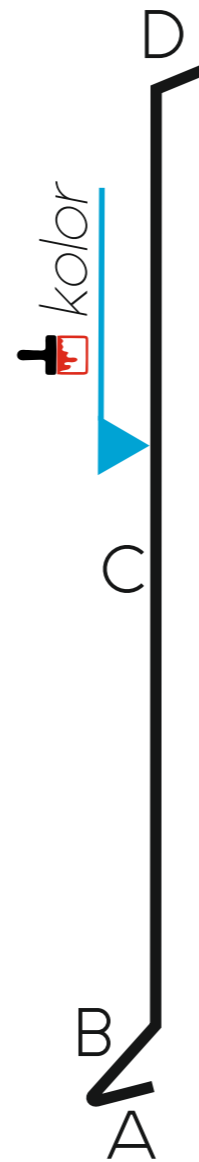

48.



100
95
75
25
5
0



Obróbka kominowa
listwa płaska

OKL2

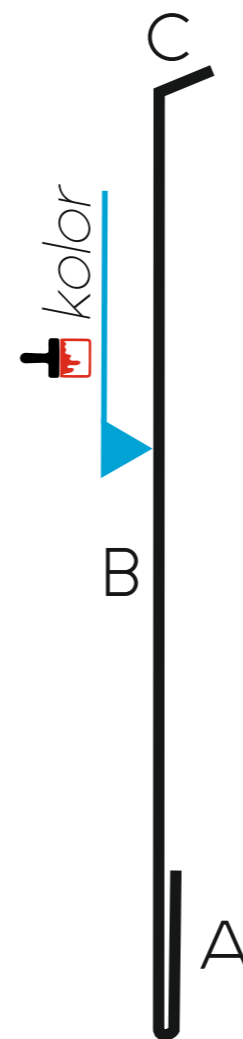

49.



100
95
75
25
5
0



Obróbka kominowa
listwa profilowana

OKL3

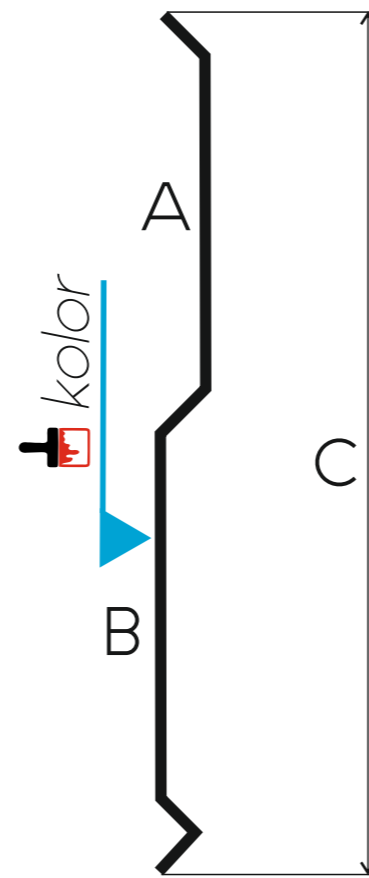

50.



100
95
75
25
5
0



Obróbka dachowa
typu pas podrynnowy

PP1

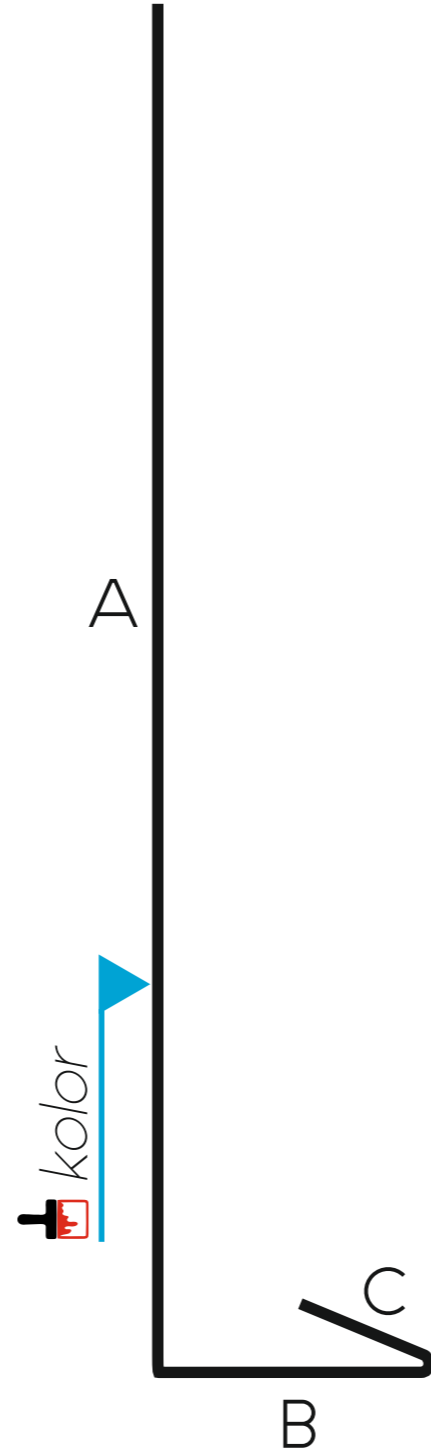

51.



100
95
75
25
5
0



Obróbka dachowa
typu pas podrynnowy

PP2

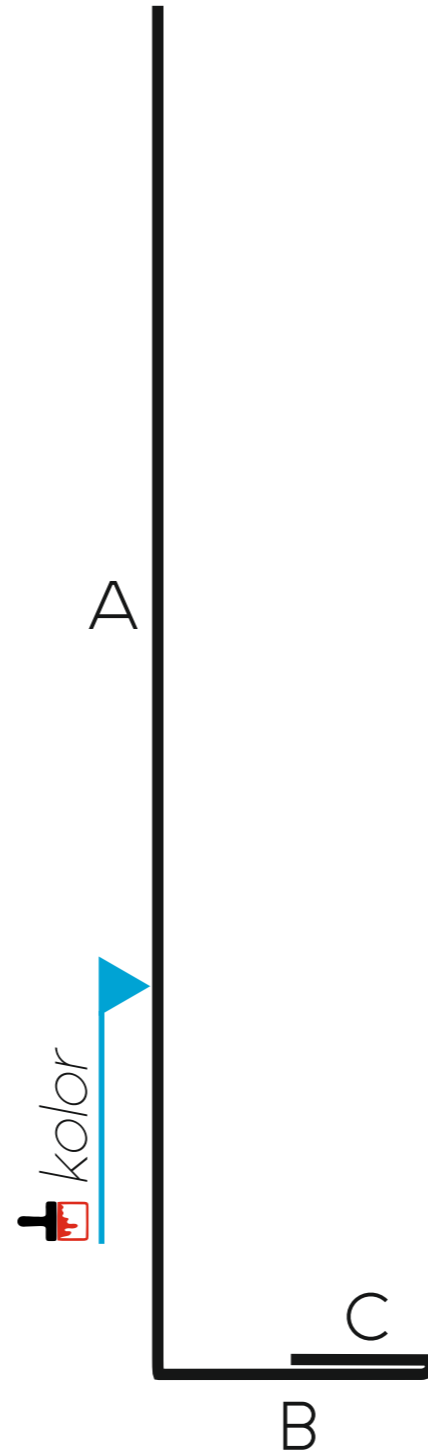

52.





Obróbka dachowa
typu pas podrynnowy

PP3

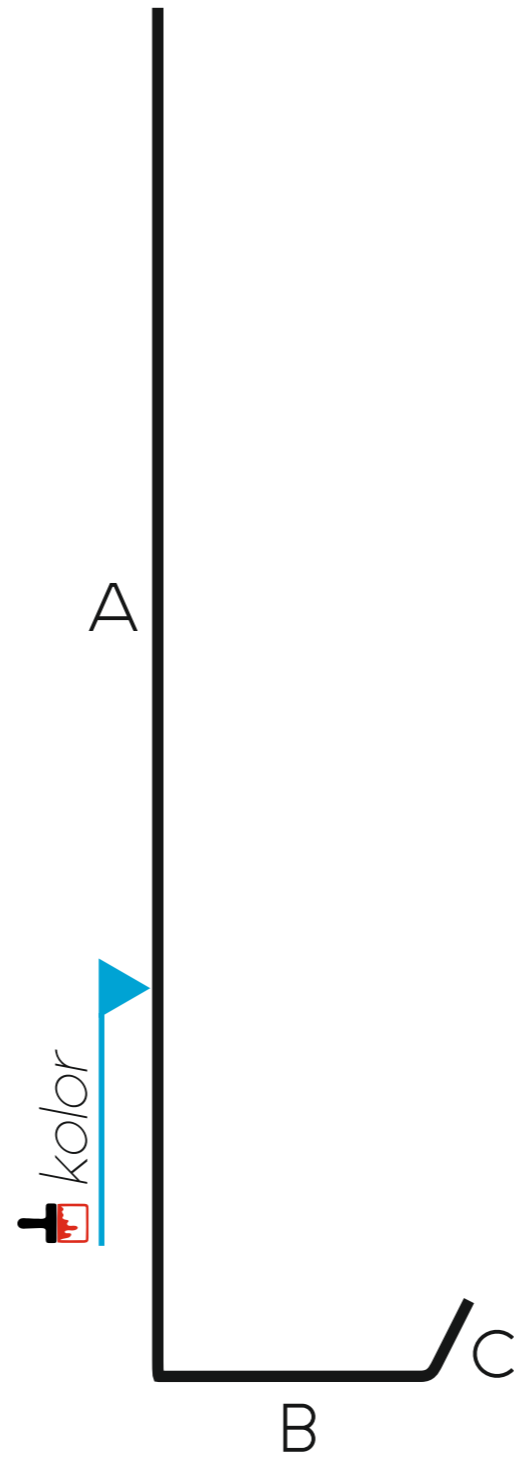

53.



100
95
75
25
5
0



Obróbka dachowa
typu pas podrynnowy

PP4

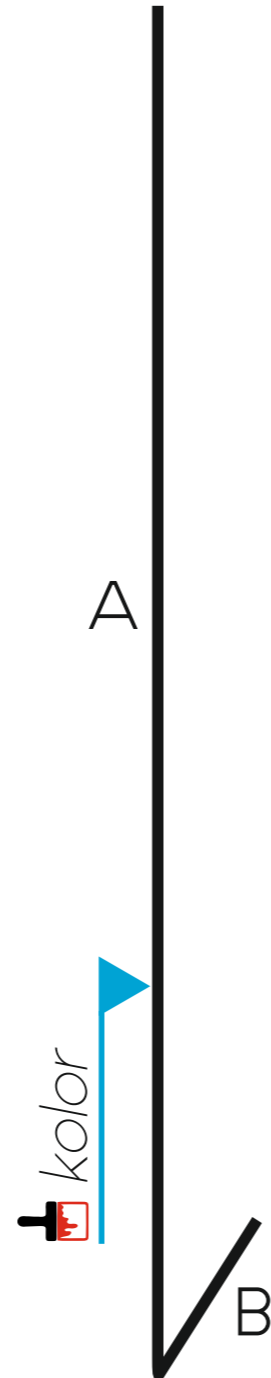

54.



100
95
75
25
5
0



Obróbka dachowa
typu pas podrynnowy

PP5

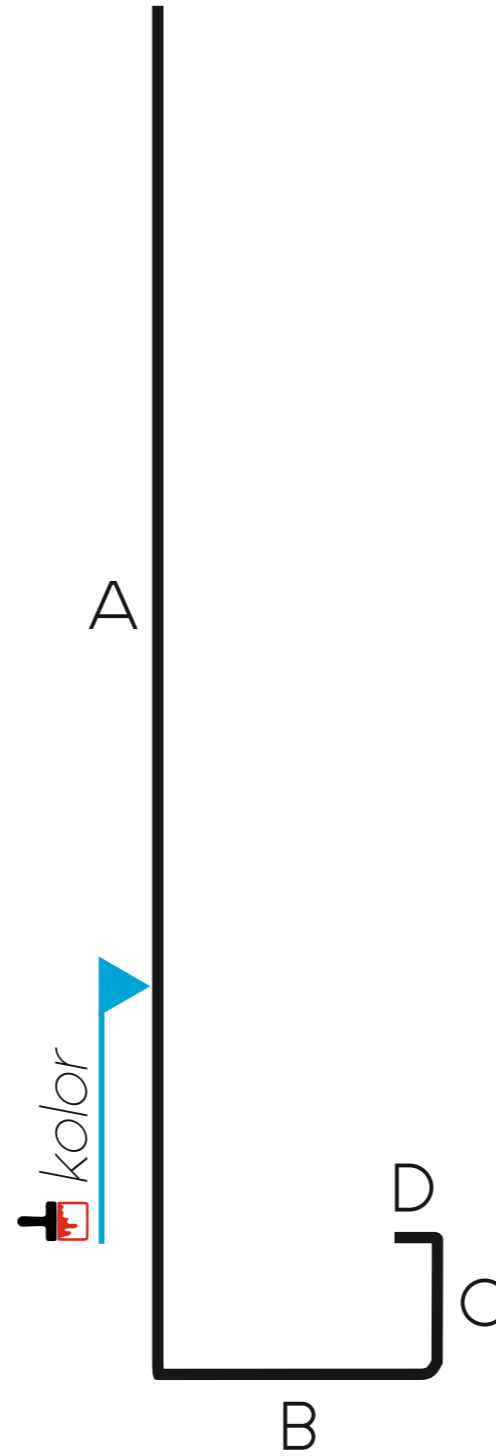

55.



100
95
75
25
5
0



Obróbka dachowa
typu pas podrynnowy

PP6

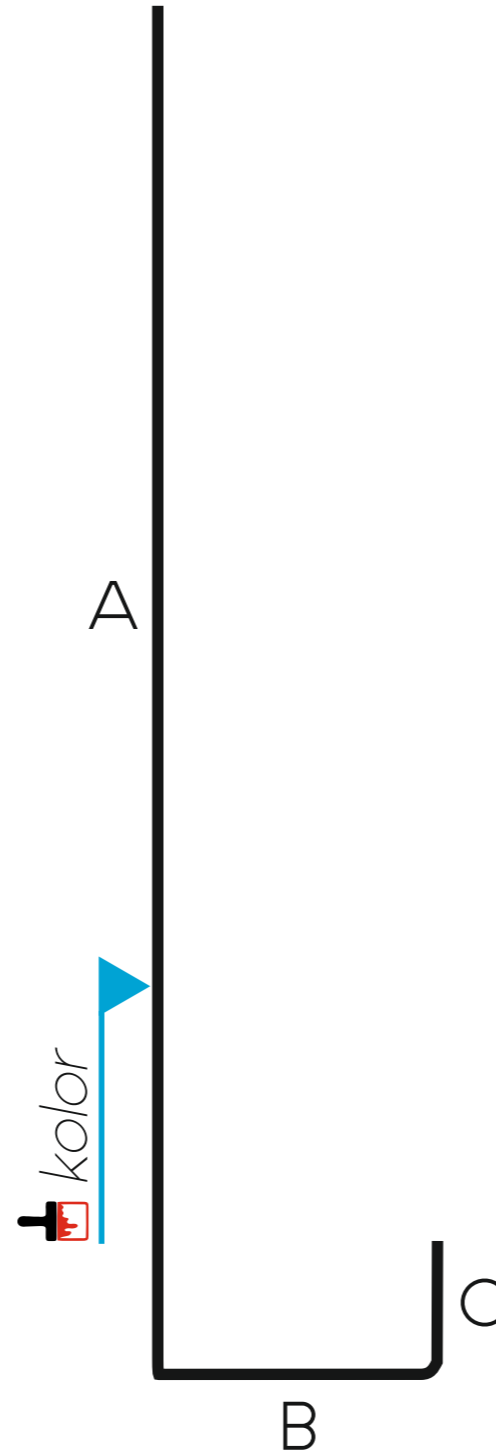

56.



100
95
75
25
5
0



Obróbka dachowa
typu pas podrynnowy

PP7

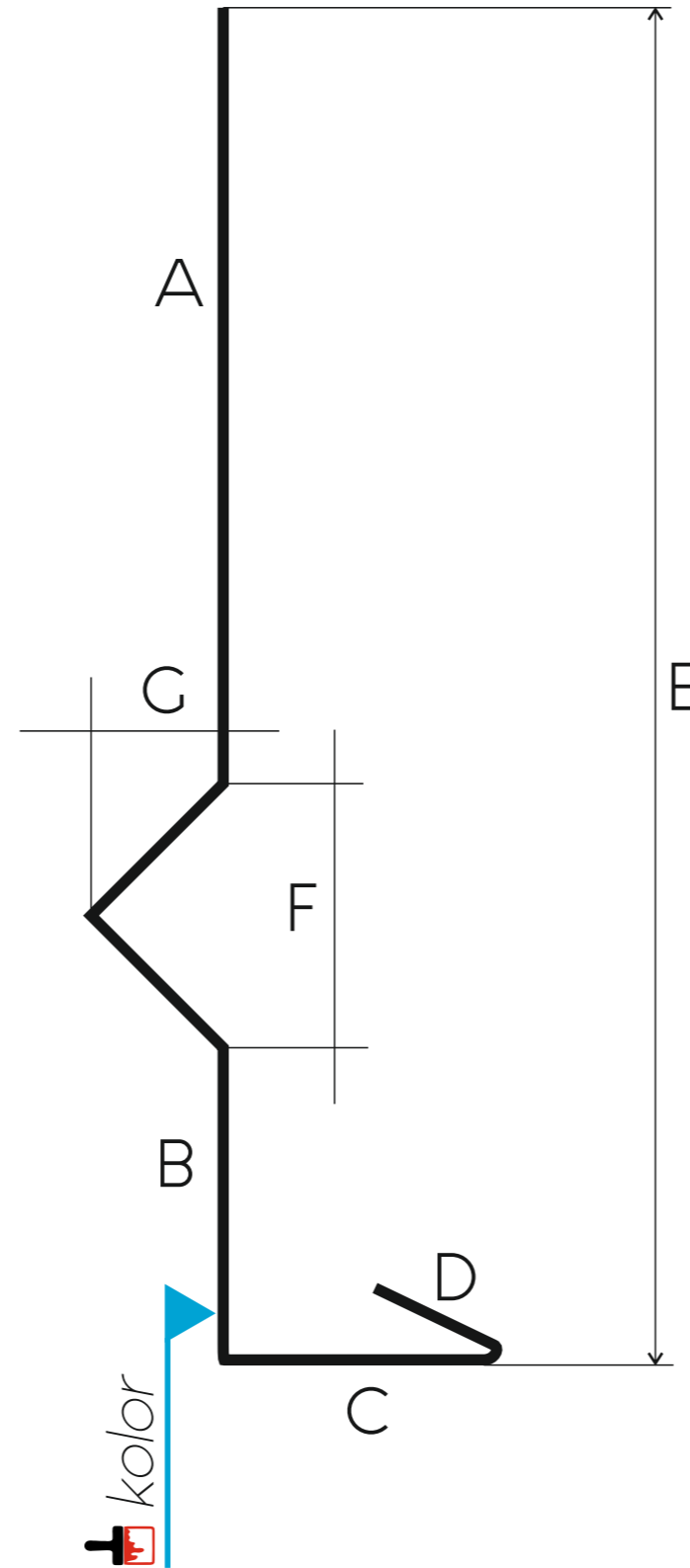

57



100
95
75
25
5
0



Obróbka dachowa
typu pas podrynnowy

PP8

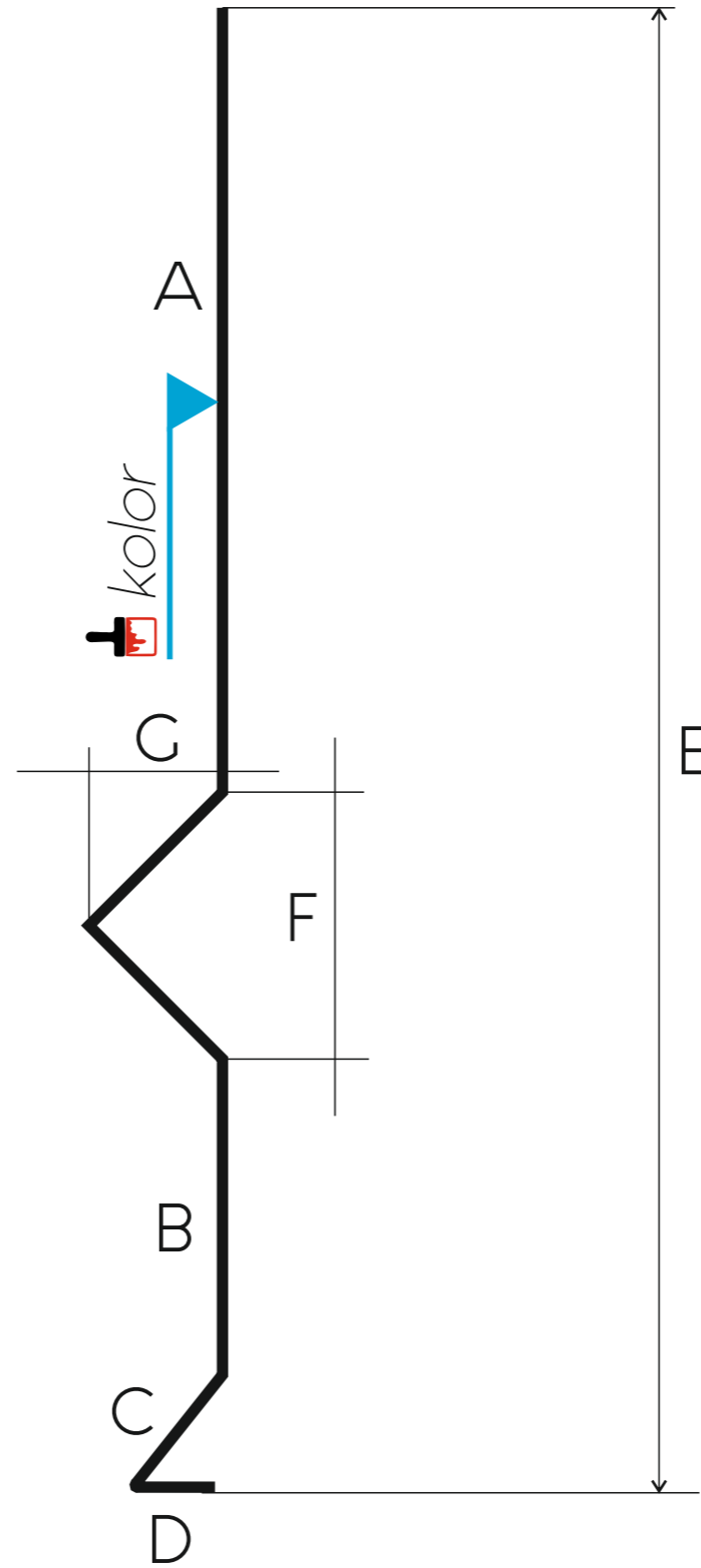

58.



100
95
75
25
5
0



Obróbka dachowa
typu pas podrynnowy

PP9

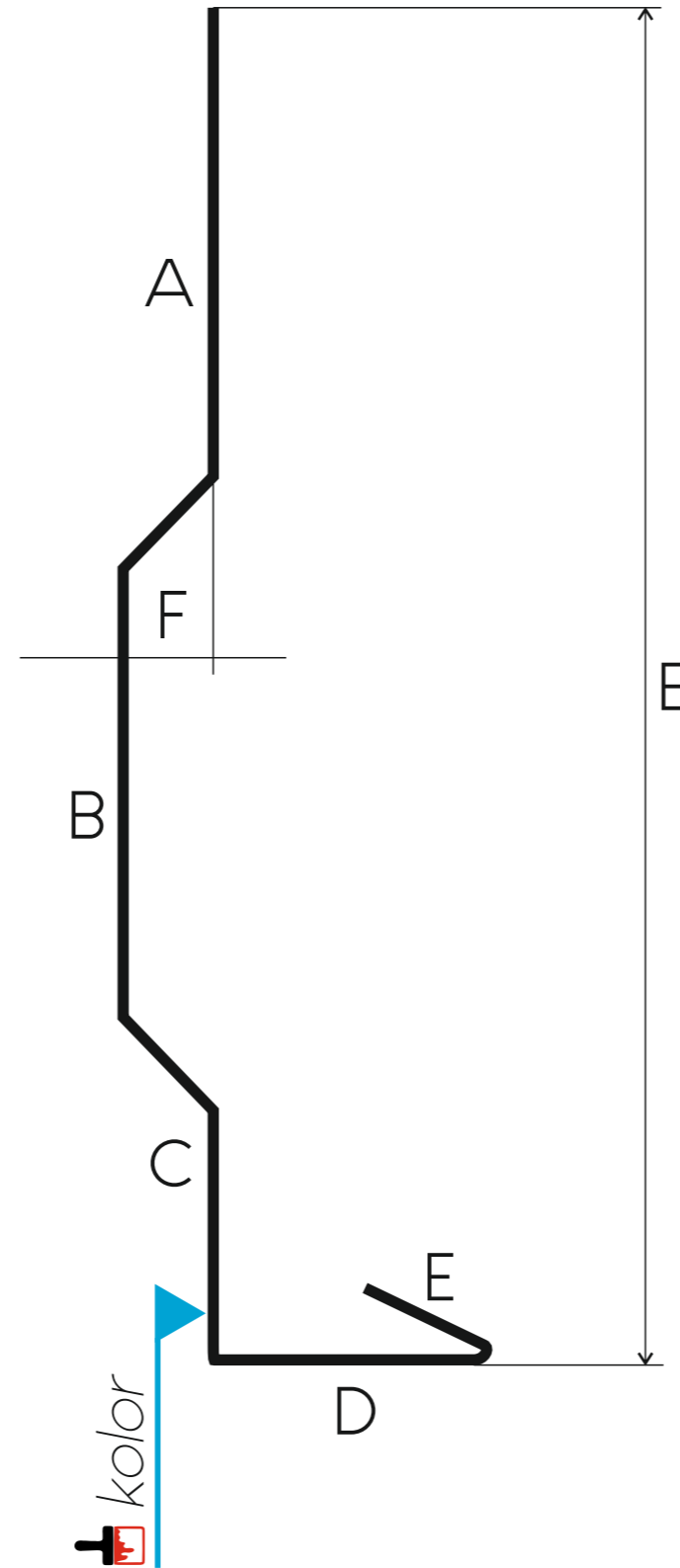

59.



100
95
75
25
5
0



Obróbka dachowa
typu pas podrynnowy

PP10

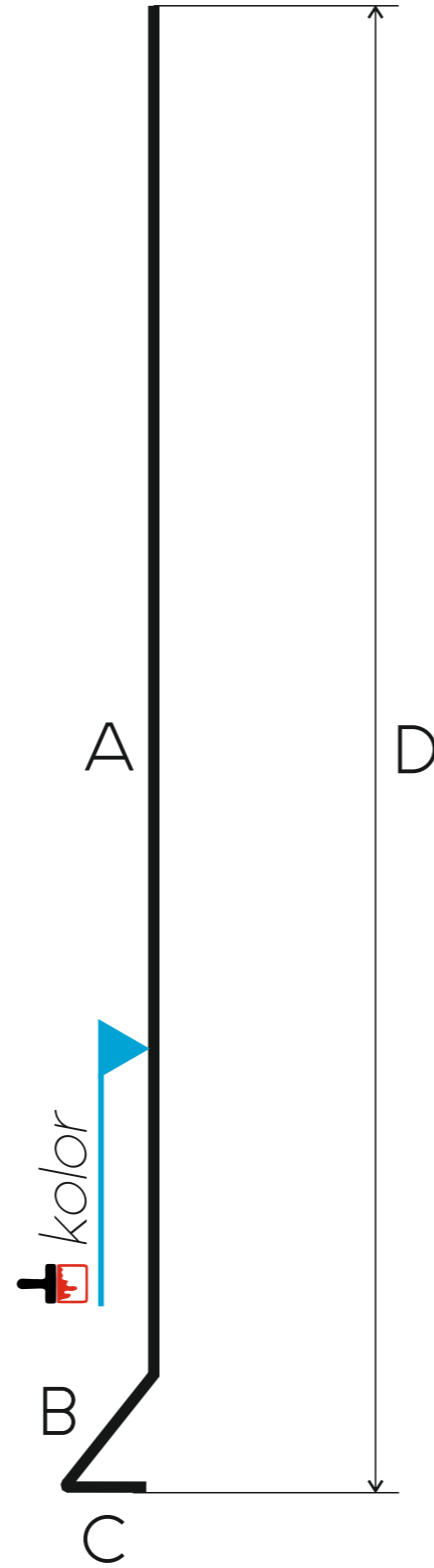

60.



100
95
75
25
5
0



Obróbka dachowa
typu pas podrynnowy

PP11

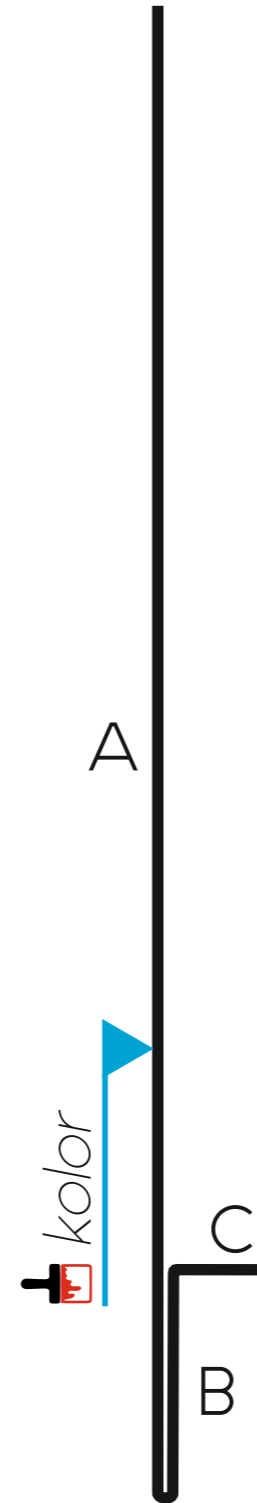

61.



100
95
75
25
5
0



Obróbka dachowa
typu pas podrynnowy

PP12

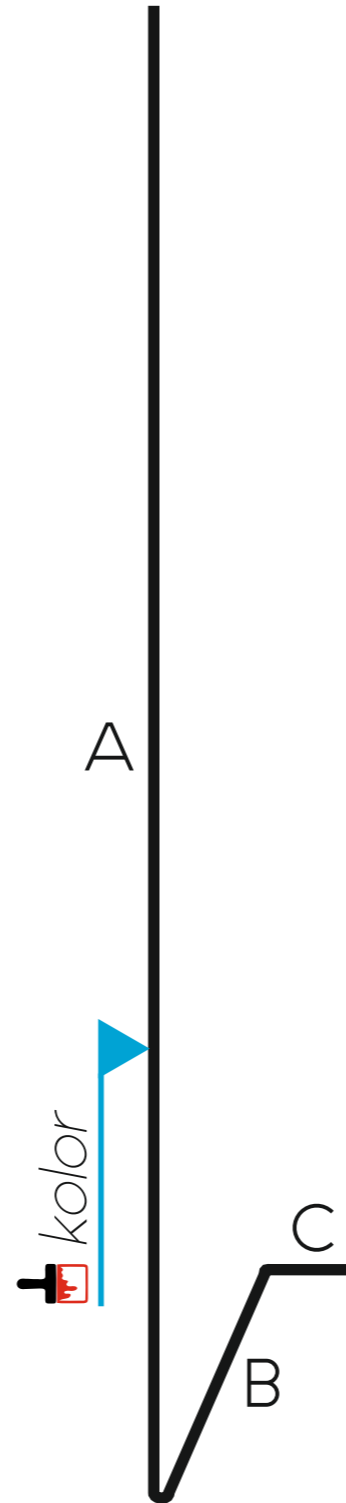

62.



100
95
75
25
5
0



Obróbka dachowa
typu pas podrynnowy

PP13

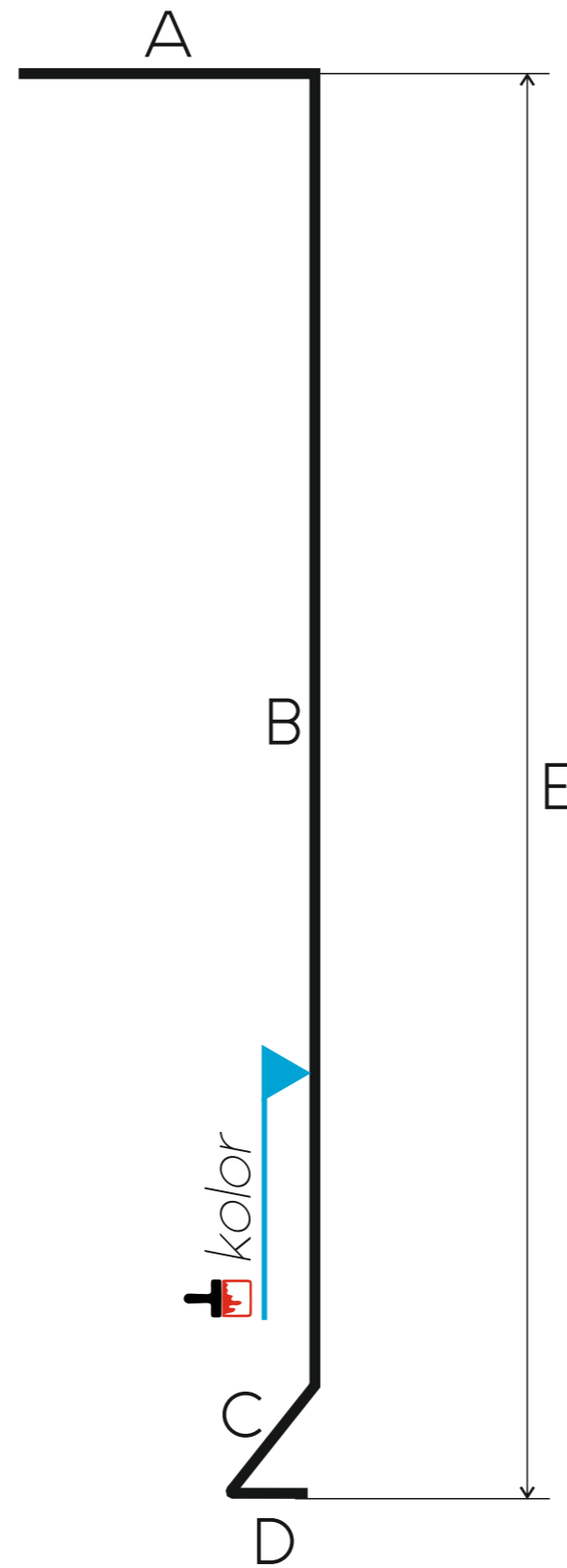

63.



100
95
75
25
5
0



Obróbka dachowa
typu pas podrynnowy

PP14

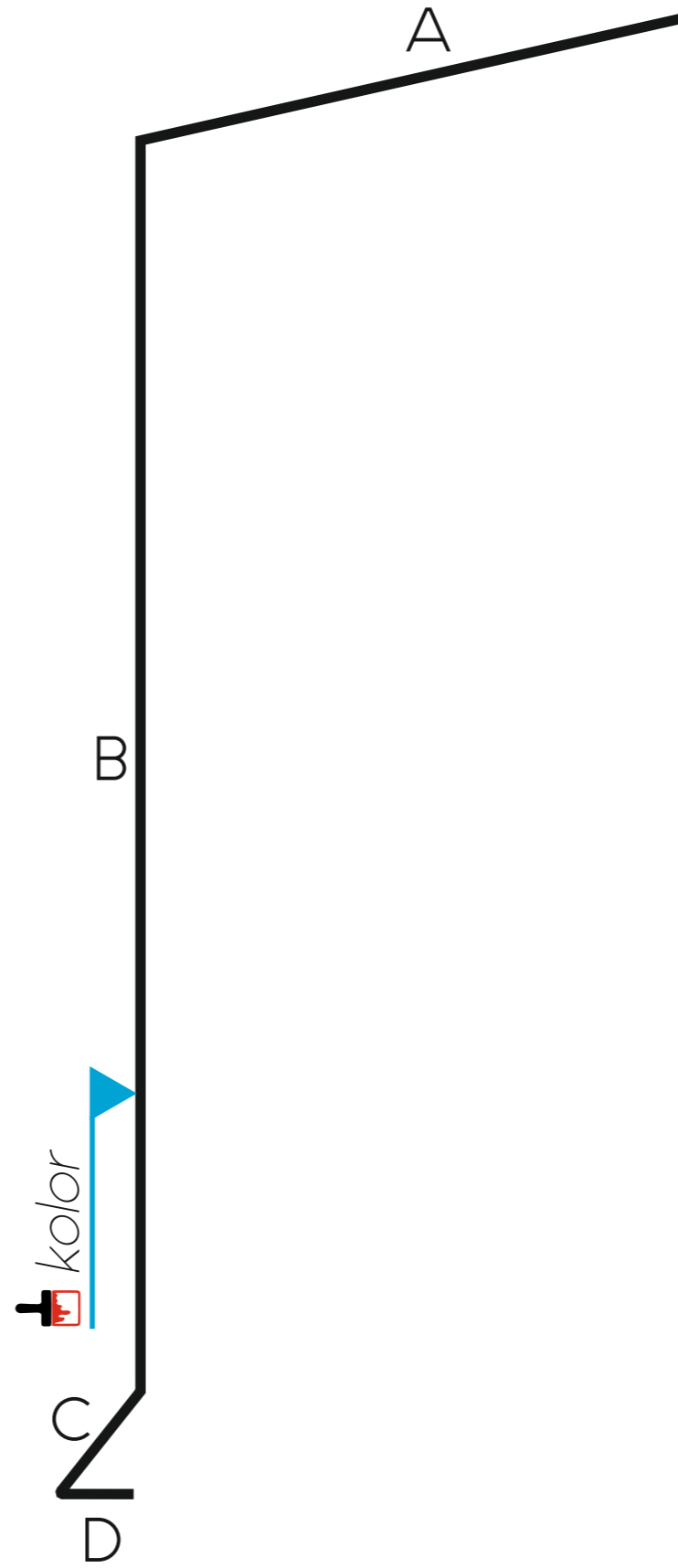

64.



100
95
75
25
5
0



Obróbka dachowa
typu pas podrynnowy

PP15

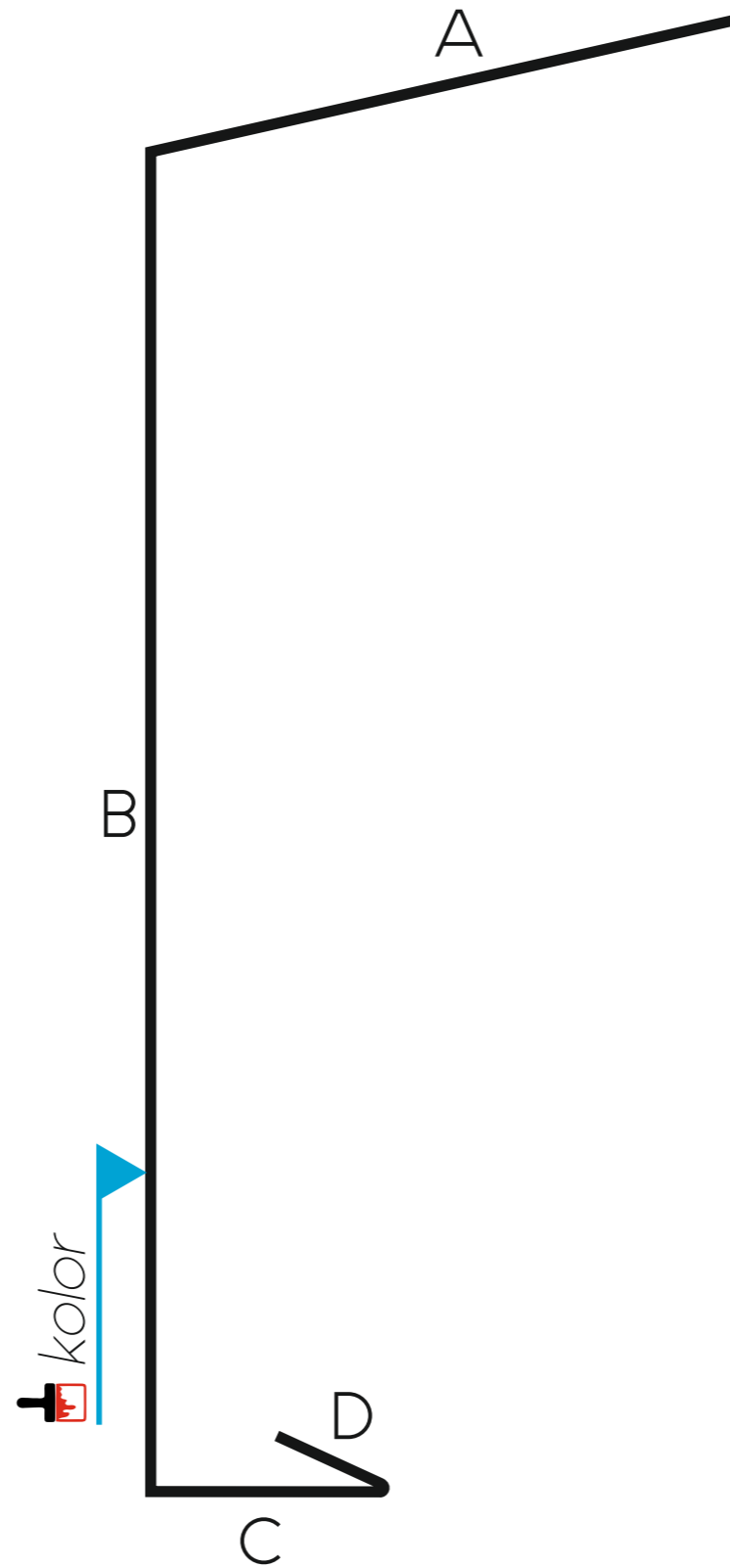

65.



100
95
75
25
5
0



Obróbka dachowa
typu pas podrynnowy

PP16

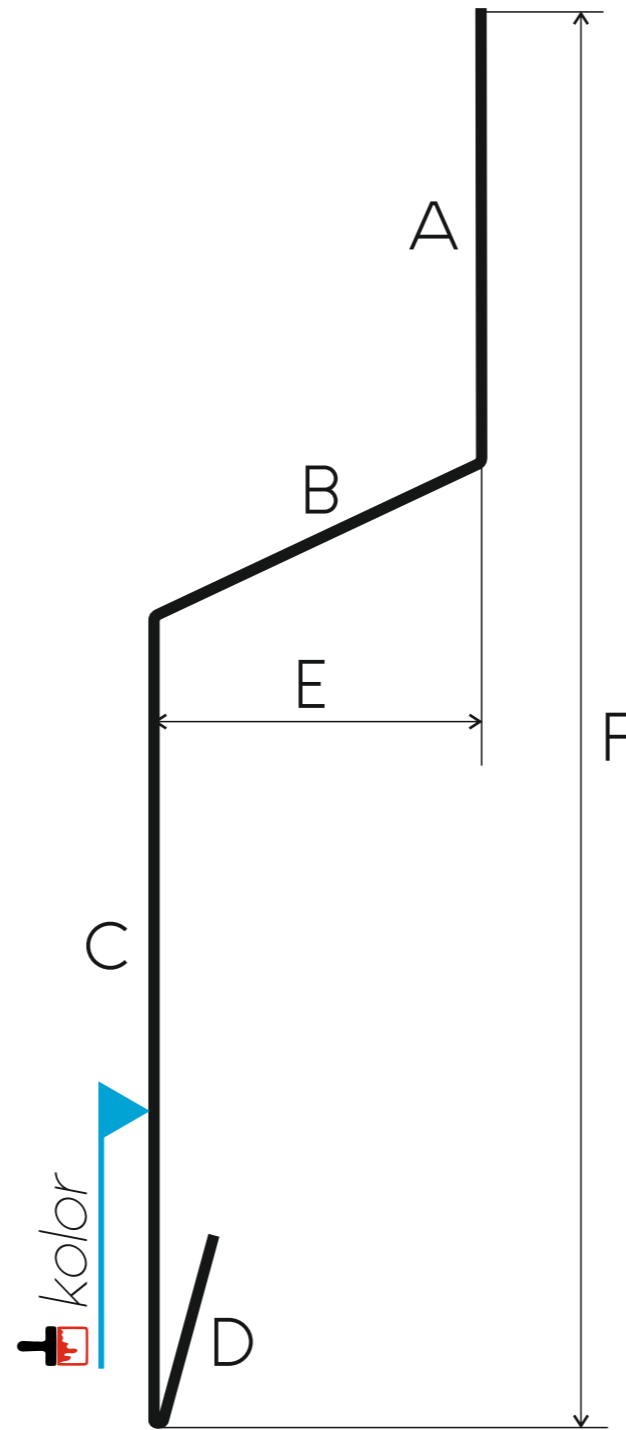

66.



100
95
75
25
5
0



Obróbka dachowa
typu pas podrynnowy

PP17

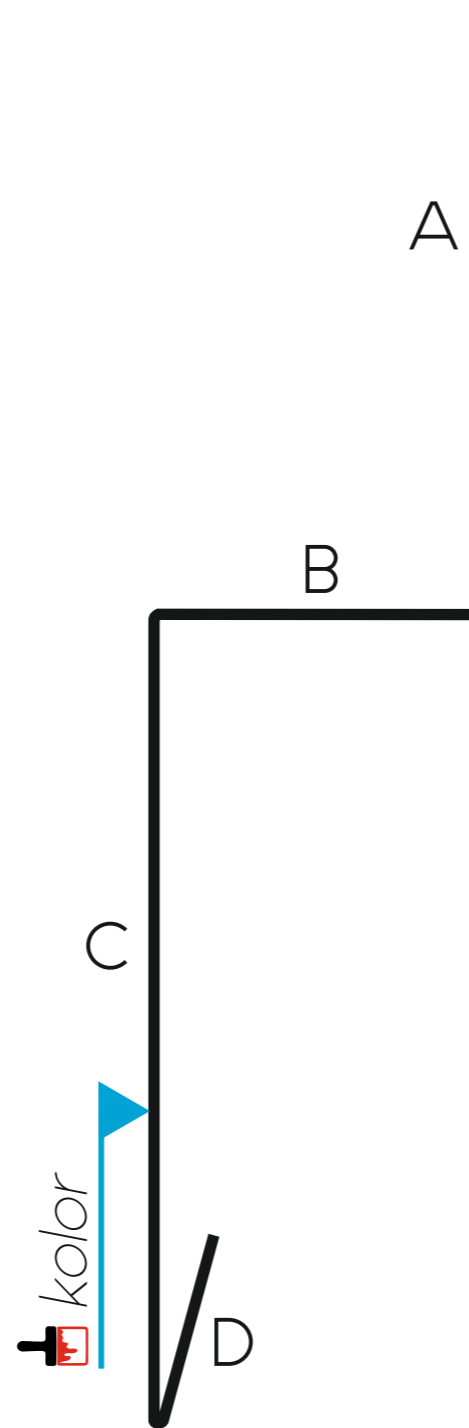

67.



100
95
75
25
5
0

J.A.W

AKCESORIA DACHOWE

J.A.W AKCESORIA DACHOWE S.C.
J.Przyborowski & A.Gierasimow & W.Karpiński
ul.Spółdzielców 20, 62-510 Konin
NIP PL 6652780665 REGON 300314812

TELEFONY KONTAKTOWE
biuro obsługi: 63 220 52 79

współwłaściciele

Jacek Przyborowski
501608862
jacek@jaw.com.pl

Artur Gierasimow
501608652
artur@jaw.com.pl

Waldemar Karpiński
506143995
waldek@jaw.com.pl

przedstawiciel handlowy

Witold Kałużny
500255904
witek@jaw.com.pl

www.jaw.com.pl

100
95
75
25
5
0